

**EPA**  
**Performance Requirements**  
**for**  
**Laboratory Fume Hoods**

**As Manufactured Performance Tests**  
**As Installed Performance Tests**  
**As Used Performance Tests**



February 26, 2009

U.S. Environmental Protection Agency  
Safety, Health and Environmental Management Division

**CONTENTS**

LIST OF TABLES .....	III
LIST OF FIGURES .....	IV
ACRONYMS AND ABBREVIATIONS .....	V
1.0 PURPOSE AND INTRODUCTION .....	1
2.0 CONSTRUCTION CRITERIA AND NFPA REQUIREMENTS .....	2
2.1 Constant Volume Bypass-Type Fume Hoods.....	2
2.2 Variable Air Volume (VAV) Hoods.....	2
2.3 Two-Position VAV or Integrated VAV Exhaust Systems.....	2
2.4 Radioactive Isotope Hoods .....	2
2.5 Perchloric Acid Hoods.....	2
2.6 Floor-Mounted (Walk-In) Hoods.....	2
2.7 Distillation Hoods .....	2
2.8 Special Purpose Hoods .....	3
2.9 Bypass Grille.....	3
2.10 Airfoil Sill.....	3
2.11 Sidewall.....	3
2.12 Interior Walls .....	3
2.13 Baffle .....	3
2.14 Light Fixture .....	4
2.15 Sash .....	4
2.16 Sash Counterbalance.....	4
2.17 Sash Plane.....	4
2.18 Sash Stops .....	4
2.19 Sash Sensor .....	4
2.20 Exhaust Outlet.....	5
2.21 Electrical Switches and Outlets .....	5
2.22 Bench Top.....	5
2.23 Work Surface .....	5
2.24 Visible Monitor and Alarm.....	5
2.25 Hood Superstructure Dimensions .....	5
2.26 Mechanical Air Supply for Low-Velocity, High-Performance Hoods.....	6
3.0 PERFORMANCE TEST CONDITIONS AND CONFIGURATIONS .....	7
3.1 Test Laboratory Conditions .....	7
3.2 Equipment Calibration.....	7
3.3 Data Recording .....	7
3.4 Sash Opening Configurations .....	8
3.5 Fume Hood AFV.....	9

4.0	PERFORMANCE TESTS .....	10
4.1	As Manufactured (AM) Performance Tests.....	11
4.2	As Installed (AI) Performance Tests.....	14
4.3	As Used (AU) Performance Tests.....	16
5.0	PERFORMANCE TEST PROCEDURES .....	19
5.1	Inspection.....	19
5.1.1	Hood Inspection.....	19
5.1.2	Laboratory Inspection.....	20
5.1.3	Exhaust System Inspection (only for use with the AM performance test).....	20
5.2	Operating Conditions Tests.....	21
5.2.1	Laboratory Environment Tests (Room Differential Pressure and Temperature).....	21
5.2.2	Cross-Draft Velocity Test.....	21
5.2.3	Face Velocity Test .....	22
5.2.4	Hood Monitor.....	24
5.2.5	Exhaust Flow and Hood Static Pressure Measurements.....	24
5.2.6	Auxiliary Air Velocity Tests.....	26
5.2.7	Dynamic VAV Response and Stability Tests .....	26
5.3	Containment Performance Tests.....	28
5.3.1	Airflow Visualization Tests (smoke).....	28
5.3.2	Tracer Gas Containment Tests (static mannequin).....	29
5.3.3	Sash Movement Effect (SME or VAV Tracer Gas Containment Test).....	32
6.0	AM AND AI FUME HOOD PERFORMANCE CRITERIA.....	34
	APPENDIX A – AM AND AI TEST FORMS AND DATA SHEETS.....	A-1
	APPENDIX B – AU TEST FORMS AND DATA SHEETS.....	B-1

**LIST OF TABLES**

Table 1. Performance Test Procedures (“As Manufactured” [AM], “As Installed” [AI], and “As Used” [AU]) .....10

Table 2. “As Manufactured” Performance Test.....11

Table 3. “As Installed” Performance Test .....14

Table 4. “As Used” Performance Test.....16

Table 5. Face Velocity Traverse Grids for Different Size Openings.....23

Table 6. Pitot Traverse Points in a Circular Duct of Known Duct Diameter .....25

Table 7. Rating of Observed Airflow Patterns.....28

Table 8. Mannequin Heights for Tracer Gas Tests of Different Fume Hood Types .....30

**LIST OF FIGURES**

Figure 1. Sash Configuration for Bench-Top Hood Equipped With Vertical Sliding Sash .....	8
Figure 2. Sash Configuration for Bench-Top Hood Equipped With Horizontal Sliding Sash .....	8
Figure 3. Sash Configuration for Distillation or Floor-Mounted LFH Equipped With Double Vertical Sliding Sashes .....	9
Figure 4. Sequence for Conducting AM and AI Performance Tests .....	13
Figure 5. Sequence for Conducting AU Performance Tests .....	18
Figure 6. Typical Bench-Top LFH .....	19
Figure 7. Probe Location and Orientation to Determine Maximum Cross-Draft Velocity Near the Hood Opening .....	22
Figure 8. Sample Grid Configurations With Fixed Probe at Center of Traverse Grid .....	23
Figure 9. Setup for VAV Response and Stability Tests .....	27
Figure 10. Placement of Mannequin and Tracer Gas Ejector for Bench-Top LFHs .....	31
Figure 11. Placement of Mannequin and Tracer Gas Ejector for Floor-Mounted (Walk-in) LFHs .....	31
Figure 12. Placement of Mannequin and Tracer Gas Ejector for Distillation LFHs Equipped With Double Vertical Sliding Sashes .....	32

## ACRONYMS AND ABBREVIATIONS

ACH	air changes per hour
ADA	Americans with Disabilities Act
AFV	average face velocity
AI	as installed
AIHA	American Industrial Hygiene Association
AM	as manufactured
AU	as used
ANSI	American National Standards Institute
ASHRAE	American Society of Heating, Refrigerating, and Air-Conditioning Engineers
BZ	breathing zone (as defined by ASHRAE 110)
CAV	constant air volume
CFM	cubic feet per minute
EPA	U.S. Environmental Protection Agency
FPM	feet per minute
GFCI	ground fault circuit interrupter
HVAC	heating, ventilating, and air conditioning
LFH	laboratory fume hood
NFPA	National Fire Protection Association
PPM	parts per million
PTP	performance test procedure
SEFA	Scientific Equipment & Furniture Association
SHEMD	Safety, Health and Environmental Management Division
SME	sash movement effect
TAB	testing, adjusting, and balancing
VAV	variable air volume

## 1.0 PURPOSE AND INTRODUCTION

This document describes the test procedures to evaluate the performance of laboratory fume hoods (LFHs) at U.S. Environmental Protection Agency (EPA) laboratories. EPA operates numerous laboratories across the nation and relies upon LFHs to provide safe working conditions. The three types of tests included in this document are as follows:

- **“As manufactured” (AM) tests**, which fume hood manufacturers perform before EPA purchases an LFH to determine whether the fume hood meets EPA’s performance criteria. *(EPA facilities must confirm that LFHs meet the performance criteria based on the performance tests in Sections 5 and 6 of this document prior to accepting the delivery of a new LFH. EPA’s Safety, Health and Environmental Management Division (SHEMD) maintains a list of manufacturers and fume hood models that have demonstrated conformance with EPA’s AM performance criteria.)*
- **“As installed” (AI) tests**, which the LFH manufacturer or a third-party, independent testing agency conducts immediately following installation and after the testing and balancing (TAB) report has been reviewed by SHEMD. These tests (1) verify proper performance integration with mechanical heating, ventilating, and air conditioning (HVAC) systems and (2) establish a benchmark for the performance of the fume hood system.
- **“As used” (AU) tests**, which EPA laboratory personnel or qualified contractors conduct annually to ensure long-term sustainable performance of the fume hood systems. These tests verify the continued long-term performance of the fume hood system.

The test procedures apply to hood types that have vertical and/or combination sashes (vertical sash with horizontal panels), including:

- Constant volume bypass hoods (bench-top, floor-mounted, and distillation types);
- Hoods designed to comply with the Americans with Disabilities Act (ADA);
- Low average face velocity fume hoods (low velocity hoods); and
- Variable air volume (VAV) hoods (conventional or special design hoods that are operated with controls that adjust airflow volumes for different sash opening configurations or occupancy conditions).

Performance requirements and construction criteria for other types of hoods and exhaust devices, such as laminar airflow equipment, biological safety cabinets, snorkels, canopy hoods, and glove boxes, are available through EPA’s Safety, Health and Environmental Management Division (202-564-1640).

LFHs must meet all of the construction requirements listed in Section 2 of this document, the performance ratings included in Section 4, and the performance criteria in Sections 5 and 6. Section 3 summarizes which performance tests listed in Section 5 are required for each AM, AI, and AU performance test.

## **2.0 CONSTRUCTION CRITERIA AND NFPA REQUIREMENTS**

All LFHs must meet the following construction criteria and National Fire Protection Association (NFPA) requirements in addition to demonstrating that they meet EPA's performance criteria using the procedures described in Section 5. These design criteria are applicable to all types and models of LFHs, except where noted in the description of the construction specifications as follows or in the most current EPA Facilities Manual Volume 2 (July 2004 or later).

### **2.1 Constant Volume Bypass-Type Fume Hoods**

Refer to EPA Facilities Manual, Volume 2, *Architecture and Engineering Guidelines*, Section 15.7.3 for specifications. (Note: Volume 2 includes two sections labeled 15.7.3; the first Section 15.7.3 includes information regarding constant volume bypass-type fume hoods.)

### **2.2 Variable Air Volume (VAV) Hoods**

Refer to EPA Facilities Manual, Volume 2, *Architecture and Engineering Guidelines*, Section 15.7.3 for specifications. (Note: Volume 2 includes two sections labeled 15.7.3; the second Section 15.7.3 includes information regarding VAV hoods.)

### **2.3 Two-Position VAV or Integrated VAV Exhaust Systems**

When multi-speed exhaust fans/variable-speed motor systems are used, the device that controls both the supply and exhaust air volumes shall be actuated by a LFH sash position sensor.

### **2.4 Radioactive Isotope Hoods**

Refer to EPA Facilities Manual, Volume 2, *Architecture and Engineering Guidelines*, Section 15.7.4 for specifications.

### **2.5 Perchloric Acid Hoods**

Refer to EPA Facilities Manual, Volume 2, *Architecture and Engineering Guidelines*, Section 15.7.5 for specifications.

### **2.6 Floor-Mounted (Walk-In) Hoods**

Sashes may be double vertical sliding, two track horizontal sliding, or a combination of vertical and horizontal sliding sashes. The fume hood must include all accessories such as tables, shelves, or tubing racks for the performance testing.

### **2.7 Distillation Hoods**

These fume hoods shall have two sashes that operate independently, allowing for an opening at the top or bottom of the hood and with releasable sash stops that allow no



more than 80 percent of the top sash open with the bottom sash closed (40 percent of maximum sash opening).

## **2.8 Special Purpose Hoods**

Refer to EPA Facilities Manual, Volume 2, *Architecture and Engineering Guidelines*, Section 15.7.6 for specifications.

## **2.9 Bypass Grille**

The bypass grill shall provide a means to reduce the face velocity as the sash is being closed. For constant volume LFHs, it shall ensure the average face velocity (AFV) does not exceed three times the design AFV as the sash is being closed.

## **2.10 Airfoil Sill**

An airfoil, which presents a streamlined appearance similar to the sides, shall be installed at the bottom of the face opening. It shall be designed in a manner that minimizes reverse airflow at the front edge of the work surface. The airfoil shall be mounted so that it minimizes turbulence, produces a smooth flow of air over the work surface, and prevents reverse flow within 6 inches of the sash plane. It may provide a means for electrical cords to exit the LFH chamber when the sash is fully closed if no other design feature exists to safely secure and channel electrical cords within or outside of the hood.

## **2.11 Sidewall**

The sidewalls shall be of a dimension suitable to accommodate the service piping necessary for operation and use of the LFH. Access to the service piping should be readily available from the interior of the fume hood. It shall have access panels for access to the hood's services. Its face shall be of an aerodynamic design to reduce turbulence of the air entering the hood.

## **2.12 Interior Walls**

The interior walls shall be flush with the face plates with minimal protrusions for at least 6 inches inside the hood. The work chamber walls, ceiling, and baffle shall be constructed of a durable material or, as specified, with a finish that shall be resistant to heat, solvents, and corrosives. The interior surfaces shall be easily maintained and cleaned.

## **2.13 Baffle**

The baffle shall be designed to provide effective capture and containment at all sash opening heights. For LFHs equipped with adjustable baffles, no baffle position shall negatively affect performance. For hoods equipped with automatic adjusting baffles, a means of identifying failure, such as a light (green/working and red/not working), shall be provided.

## **2.14 Light Fixture**

Typically, a two-tube fluorescent light fixture of the longest practical length (up to 4 feet) shall be provided at the top of the hood. If an alternative lighting design is accepted by EPA, it should be noted on the performance testing documents as to why it is acceptable. It shall provide at least 100 foot-candles of light at the work surface. It shall be designed to accommodate replacement of fluorescent tubes from the exterior of the hood. If LFH enclosure panels (e.g., hood-to-ceiling enclosures) are required, access shall be provided to accommodate replacement of fluorescent tubes. The tubes shall be shielded from the hood interior by a tempered glass panel sealed into the hood body. In LFHs where explosive substances will be used, appropriate explosion-proof light fixtures shall be used. If tubes are provided, they shall be energy efficient (at least T-8) and contain the lowest concentration of mercury that is commercially available.

## **2.15 Sash**

The glass material used in the sash shall be a minimum of 7/32 inches thick and constructed of clear laminated safety glass. If the sash has a frame, it shall be composed of 18-gauge metal, at a minimum, and shall have no metal-to-metal contact with the LFH jamb during operation. The sash frame-to-glass junction shall be sealed to prevent vapor leakage and prevent items being trapped or caught between the glass/glazing and the frame.

## **2.16 Sash Counterbalance**

The sash shall be weight-balanced so that when left at any height, it remains at that position without creeping up or down. The sash shall move smoothly with the use of one hand at any point along the bottom edge, with a force of 5 pounds or less. In the event of malfunction, the sash counterbalance shall be accessible from the outside of the hood without requiring disassembly or removal of the hood superstructure.

## **2.17 Sash Plane**

The plane of the sash shall be defined as the vertical outside surface plane of the glass on the outermost sash panel.

## **2.18 Sash Stops**

The LFH shall have releasable sash stops that limit the sash height at the design sash open position (80 percent of the maximum opening height for vertical sash fume hoods).

## **2.19 Sash Sensor**

The sash sensing device for VAV fume hoods shall provide a signal that indicates the sash position with a tolerance of  $\pm 0.25$  inches.

## 2.20 Exhaust Outlet

A suitable fume hood collar shall provide a leak-free connection to the LFH exhaust system.

## 2.21 Electrical Switches and Outlets

This equipment shall be of the ground fault circuit interrupter (GFCI) type and meet the requirements of NFPA Standard 70, *National Electric Code*. A minimum of one duplex 120-volt outlet per side or the number required by EPA specifications shall be provided, and they shall be located on the exterior of the LFH.

## 2.22 Bench Top

The work surface shall be of one-piece construction with a recess of at least 3/8 inches. It shall also have a ledge all around its perimeter. The ledge at the front of the work surface shall not extend more than 3 inches beyond the sash plane to prevent materials from being placed or stored on the ledge. The work surface may have a line embedded in it from side to side at least 6 inches to the rear of the plane of the sash to indicate that all equipment and operations must be located behind the line. The interface between the work surface and the hood liner must be sealed to prevent leakage.

## 2.23 Work Surface

The bench top shall have a 3/8-inch recessed work surface indicating the area for conducting experiments, containment of spills. The length and width of the recessed area determines the minimum exhaust volume for the LFH.

## 2.24 Visible Monitor and Alarm

The hood shall have an airflow digital display monitor with a low-flow audible and visible alarm that can be calibrated to alarm at 90 percent of the specified AFV (e.g., 54 feet per minute (fpm) when AFV is 60 fpm, and 90 fpm when AFV is 100 fpm). The monitor shall indicate airflow in a quantitative manner with a minimum accuracy of  $\pm 5$  percent of the specified AFV or its equivalent. The monitor display and alarm conditions shall be clearly visible in the installed location.

## 2.25 Hood Superstructure Dimensions

The following dimensions shall apply unless different dimensions are specified in writing by EPA. The superstructure outside dimensions for bench-mounted hoods shall not exceed 65 inches in height or 36 inches in depth. Low-velocity fume hoods may have a depth up to 39 inches. The outside length dimension shall be 48, 60, 72, or 96 inches, as specified by EPA. Interior clear working height shall be at least 47 inches, measured from the work surface. The minimum sash opening, including the space below the bottom airfoil, shall be at least 28 inches in height.

## **2.26 Mechanical Air Supply for Low-Velocity, High-Performance Hoods**

Laboratory fume hoods that have air introduced mechanically at the face of the fume hood to provide containment performance are unacceptable for use in EPA laboratories. Satisfactory containment shall be achieved through aerodynamic design features and supply air delivered away from the fume hood face.

### **3.0 PERFORMANCE TEST CONDITIONS AND CONFIGURATIONS**

The EPA performance tests use a modified application of the American National Standards Institute (ANSI)/ American Society of Heating, Refrigerating, and Air-Conditioning Engineers' (ASHRAE) Standard 110, *Method of Testing Performance of Laboratory Fume Hoods* (herein referred to as ANSI/ASHRAE 110). The tests are intended to verify the performance of a fume hood operating in accordance with EPA specifications under the conditions described as follows.

#### **3.1 Test Laboratory Conditions**

Unless otherwise specified, all the requirements of ANSI/ASHRAE 110 shall be met. In addition, the test laboratory must have mechanical air supply systems capable of maintaining a temperature of 72 degrees Fahrenheit  $\pm$ 5 degrees. The test laboratory must be maintained at a negative differential pressure of 0.005 to 0.05 inches of water gage with respect to adjacent non-laboratory spaces.

#### **3.2 Equipment Calibration**

Unless otherwise specified, the equipment and instruments used during EPA's performance tests shall meet the specifications in ANSI/ASHRAE 110. In addition, the model, serial number, and recent calibration information for each piece of test equipment shall be recorded and provided with each performance test report. The following procedures verify that test instruments are properly calibrated and operating in compliance with the manufacturer's specifications.

1. Record the name of the manufacturer, model number, and serial number of all test equipment.
2. Confirm that all thermoanemometers (velocity meters) and pressure meters to be used during the tests have been calibrated within one year of the test date, and verify that calibration certificates are available (AM, AI, and AU performance tests). All equipment must be traceable to the National Institute of Standards and Technology with signed and dated calibration less than one calendar year prior.
3. Verify that the tracer gas detector and tracer gas ejector have been calibrated within eight hours preceding the tests and within eight hours following the tests (AM and AI performance tests).
4. Verify ejector flow rate (AM and AI performance tests).

#### **3.3 Data Recording**

The results of each test shall be recorded on EPA's fume hood performance data sheets or equivalent. (See Appendix A of this document for data sheets.)

### 3.4 Sash Opening Configurations

EPA requires tests to be conducted at a variety of sash openings depending on the sash type.

- **Single Vertical Sash:** Bench-top hoods equipped with a vertical sash shall be tested at the 100-percent maximum opening, the 80-percent (design) sash opening, and the 6-inch sash opening height, as shown in Figure 1.

**Figure 1. Sash Configuration for Bench-Top Hood Equipped With Vertical Sliding Sash**

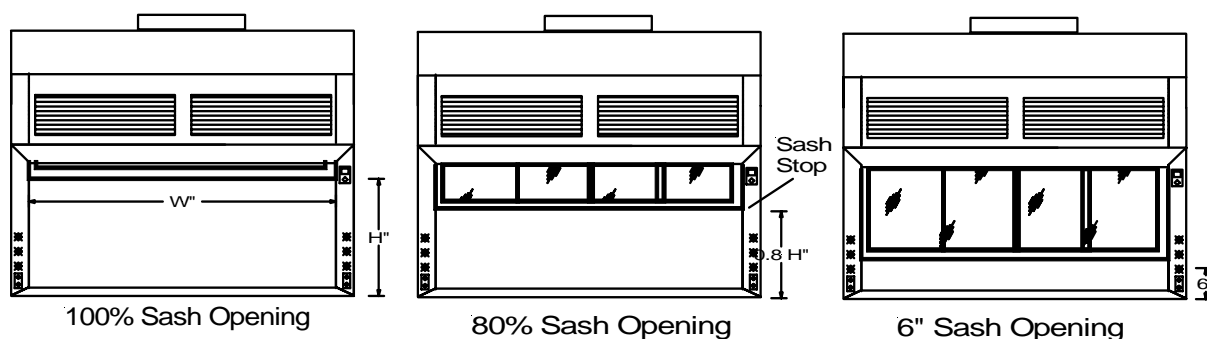

- **Horizontal Sash Hood:** The required sash openings for hoods equipped with horizontal sashes are shown in Figure 2 and include the maximum left, center, and right opening. Unless otherwise specified, the design sash opening for horizontal sashes shall not exceed a width of 30 inches.

**Figure 2. Sash Configuration for Bench-Top Hood Equipped With Horizontal Sliding Sash**

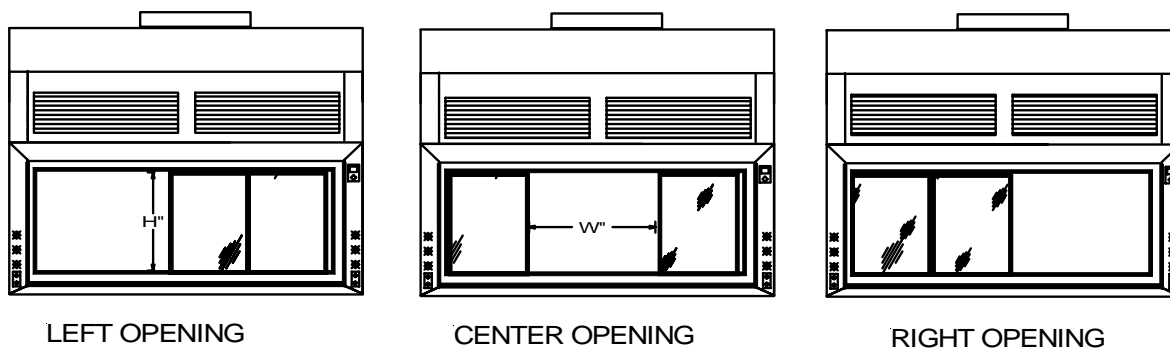

- **Combination Sash Hoods:** Hoods equipped with combination sashes must be tested at the vertical and horizontal sash openings as shown in Figures 1 and 2.
- **Double Vertical Sash Hoods:** Unless otherwise specified, hoods equipped with double vertical sashes must be tested with sashes configured as shown in Figure 3. The design sash opening shall be with the top sash 80 percent open (with sash stops for the top sash at 80 percent open) and the bottom sash fully closed. A releasable sash stop shall limit the sashes from being open more than 40 percent of the maximum opening achieved with both sashes fully open.

**Figure 3. Sash Configuration for Distillation or Floor-Mounted LFH Equipped With Double Vertical Sliding Sashes**

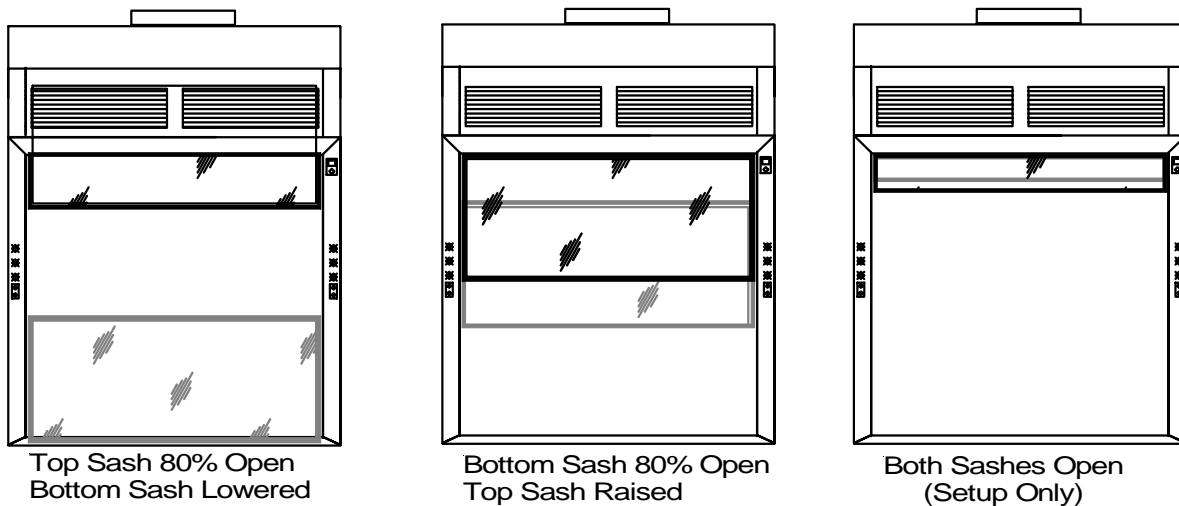

### 3.5 Fume Hood AFV

For VAV system fume hoods designated as “low-flow”, “low-velocity”, or “high-performance” shall be tested at the 100 percent sash opening with an AFV of 60 fpm (-0 to +10 percent) and at the design sash opening (i.e., 80 percent vertical sash opening) at an AFV of 60 fpm (-0 to +10 percent). For conventional (standard) LFHs, unless otherwise specified, the tests shall be conducted at the 100 percent sash opening with the resultant face velocity of approximately 80 fpm (-0 to +10 percent) and at the design sash opening (i.e., 80 percent vertical sash opening) with an AFV of 100 fpm (-0 to +10 percent).

#### 4.0 PERFORMANCE TESTS

Performance tests are conducted to evaluate the capability of LFHs to meet EPA design, construction, and performance criteria. The tests are based on guidelines and recommendations contained in:

- ANSI/American Industrial Hygiene Association (AIHA) Z9.5 *American National Standard for Laboratory Ventilation*;
- ANSI/ASHRAE Standard 110, *Method of Testing Performance of Laboratory Fume Hoods*; and
- The Scientific Equipment & Furniture Association (SEFA) document entitled *Laboratory Fume Hoods Recommended Practices*.

For all referenced standards, the most recent revisions apply. Unless otherwise specified, all terms used in this document are defined as described in ANSI/ASHRAE 110. The test procedures have been modified where appropriate to accommodate EPA-specific requirements.

Table 1 lists the elements that comprise LFH performance testing and indicate when each component is required. Section 5 provides a detailed description of the procedures that should be followed for each of the testing elements listed in Table 1.

**Table 1. Performance Test Procedures**  
 (“As Manufactured” [AM], “As Installed” [AI], and “As Used” [AU])

Laboratory Fume Hood Performance Test Procedures	AM	AI	AU
<b>Inspections</b>			
Hood inspection	X	X	X
Laboratory inspection	X	X	X
Exhaust system inspection	X	N/A	N/A
<b>Operating Conditions Tests</b>			
Lab Environment Tests: • Room differential pressure • Room temperature	X	X	X
Cross-draft velocity tests	X	X	X
Face velocity test	X	X	X
Hood monitor	X	X	X
Exhaust flow and hood static pressure measurement	X	X <sup>1</sup>	N/A
Auxiliary air velocity tests	X	X	X
Dynamic VAV response and stability tests	X	X	X
<b>Containment Performance Tests</b>			
Airflow visualization tests (smoke)	X	X	X
Tracer gas containment test (static mannequin)	X <sup>2</sup>	X <sup>2</sup>	N/A
Sash movement effect test (VAV tracer gas containment test)	X	X	N/A

Notes:

N/A - Test not applicable.

<sup>1</sup> Refer to testing and balancing (TAB) report for exhaust flow data (TAB must precede AI performance tests).

<sup>2</sup> All low-velocity LFHs or as deemed necessary by EPA SHEMD must be SF<sub>6</sub> tracer gas tested.



#### 4.1 As Manufactured (AM) Performance Tests

The AM tests are conducted prior to acceptance or purchase of any type, model, or size of fume hood. These tests evaluate the design and performance of the fume hood under prescribed operating conditions. For acceptance of any fume hood, the following conditions apply to AM tests:

1. The LFH manufacturer, in a test facility provided by the manufacturer, and at no cost to the government, shall verify the proper performance of the fume hood in accordance with EPA's performance criteria.
2. All AM tests shall be successfully conducted in the presence of an EPA representative prior to model acceptance
3. The LFH manufacturer shall contact SHEMD to coordinate its observation of the AM performance tests at least 45 days in advance of the proposed test date and set a firm testing schedule 15 work days in advance of the established test date.
4. The LFH manufacturer shall provide EPA with the specifications and shop drawings and any other descriptive information for the LFH to be tested.
5. An EPA representative shall witness the AM performance tests to observe the test procedure and to aid in EPA's verification of the results. Failure to meet performance requirements is cause for rejection of the LFH. EPA reserves the right to verify calibration of test equipment, photograph or videotape the tests, or take independent measurements during the tests.
6. When the LFH manufacturer renames, sells, or transfers the model design to a new company/entity or insignificantly redesigns a fume hood model, EPA may adopt the hood based on the existing approved model data. EPA would adopt the pre-existing model's data only if EPA/SHEMD believes that the change does not negatively impact hood performance. The LFH manufacturer must provide an updated drawings and list of components that have been modified in any way from the previously approved model.

Refer to Table 2 for a description of the applicable tests, operating configurations, and criteria for the AM fume hood performance evaluation. Figure 4 provides a flow chart showing the recommended sequence for conducting the AM tests.

**Table 2. "As Manufactured" Performance Test**

AM Tests	Description/Configuration/Condition	Criteria
<b>Inspection</b>		
Laboratory Hood		Must comply with EPA specifications.
Laboratory		
Exhaust System		

**Table 2. “As Manufactured” Performance Test**

AM Tests	Description/Configuration/Condition	Criteria
<b>Operating Conditions Tests</b>		
Laboratory Environment Tests	Room Differential Pressure (Doors Closed)	(-) 0.005 to (-) 0.05 inches of water gage
	Room Temperature (Doors Closed)	72 ± 5 degrees Fahrenheit
Cross-Draft Velocity Test	Vertical 80% Open	30-second average cross-draft velocity ≤30 fpm
	Horizontal Max Center Opening	
Face Velocity Test	Vertical 100% Open	Standard Fume Hoods, constant volume <ul style="list-style-type: none"> <li>• Target AFV = 80 fpm (-0/+10 fpm)</li> </ul> Low-Velocity Fume Hoods <ul style="list-style-type: none"> <li>• Target AFV = 60 fpm (-0/+6 fpm)</li> </ul>
	Vertical 80% Open	Standard Fume Hoods, constant volume <ul style="list-style-type: none"> <li>• Target AFV = 100 fpm (-0/+10 fpm)</li> </ul>
	Horizontal Max Openings (Left, Center, and Right)	Standard Fume Hoods <ul style="list-style-type: none"> <li>• Target AFV ≥100 fpm (-0/+10 fpm)</li> </ul> Low-Velocity Fume Hoods <ul style="list-style-type: none"> <li>• Target AFV ≥60 fpm (-0/+6 fpm)</li> </ul>
	Vertical Sash 6 in. Open	AFV < 300 fpm
Hood Monitor	All sash configurations used for face velocity tests	Indicated velocity or flow ≤5% variation from corresponding measured value
Exhaust Flow and Hood Static Pressure Measurement	Vertical Sash 80% Open	<ul style="list-style-type: none"> <li>• Manufacturer’s specified flow ±5% to achieve EPA AFV criteria</li> <li>• Hood static pressure ≤0.25 in. w.g.</li> </ul>
	Horizontal Sash Max Center Opening	
	Sashes Closed	
Dynamic VAV Response and Stability Tests	Vertical 80% Open	<ul style="list-style-type: none"> <li>• Response time ≤5 seconds</li> <li>• Flow stability ≤10% variation</li> </ul>
	Horizontal Max Opening	
<b>Containment Performance Tests</b>		
Airflow Visualization Tests (smoke)	Vertical 100% Open	No visible escape beyond plane of sash
	Vertical 80% Open	
	Horizontal Max Openings (Left, Center, and Right)	
Tracer Gas Containment Tests (static mannequin)	Vertical 100% Open <ul style="list-style-type: none"> <li>• Left, Center, and Right Test Positions</li> <li>• Tall Mannequin Height, 23 in. BZ</li> <li>• Short Mannequin Height, 18 in. BZ</li> </ul>	<ul style="list-style-type: none"> <li>• Average 5-minute concentration ≤0.05 ppm</li> <li>• Maximum 30-second rolling average ≤0.1 ppm</li> <li>• Peak concentration ≤0.5 ppm</li> </ul>
	Vertical 80% Open <ul style="list-style-type: none"> <li>• Left, Center, and Right Test Positions</li> <li>• Tall Mannequin Height, 23 in. BZ</li> <li>• Short Mannequin Height, 18 in. BZ</li> </ul>	
	Horizontal Max. Left, Center, and Right Openings <ul style="list-style-type: none"> <li>• Center Position Test Position</li> <li>• Tall Mannequin Height 23 in. BZ</li> <li>• Short Mannequin Height 18 in. BZ</li> </ul>	
	Opening Scan <ul style="list-style-type: none"> <li>• Vertical 80% Open</li> <li>• Horizontal Max Left, Center, and Right Openings</li> </ul>	
Sash Movement Effect Test (VAV Tracer Gas Containment Test)	Vertical 80% Open (Center)	
	Horizontal Max Center Opening	

**Figure 4. Sequence for Conducting AM and AI Performance Tests**

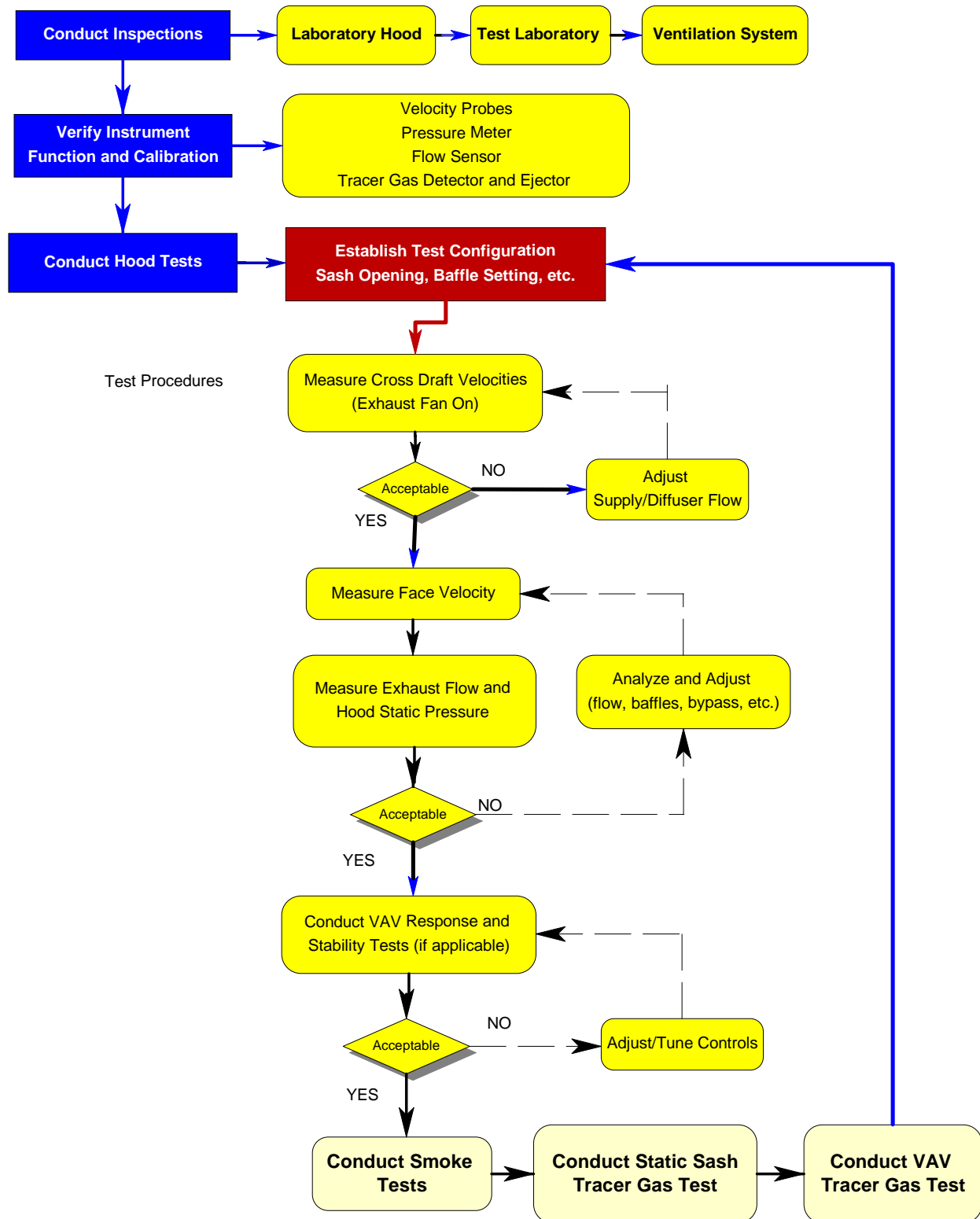

## 4.2 As Installed (AI) Performance Tests

The AI tests evaluate fume hood performance under the design operating conditions. They are conducted after testing, adjustment, and balance (TAB) and commissioning of the air supply and ventilation systems, but prior to occupancy and use of the hoods. For acceptance of any fume hood, the following conditions apply to AI tests:

1. The installer shall ensure that all fume hood components are properly installed and operating according to the manufacturer's specifications, prior to the AI performance testing.
2. The AI performance tests shall be conducted by the LFH manufacturer or manufacturer's representative, or a qualified third-party, independent testing agency with ASHRAE 110 experience and capabilities.
3. The installer shall contact SHEMD to coordinate its observation of the AI performance tests at least 45 days in advance of the proposed test date and set a firm testing schedule 15 days in advance of the established test date.
4. The installer shall provide EPA with the specifications, shop drawings, and any other descriptive information for the LFH to be tested.
5. An EPA representative shall witness the performance tests to observe the test procedure and to aid in EPA's verification of the results. Failure to meet performance requirements is cause for rejection of the LFH, modification of the laboratory, or adjustment of the ventilation systems. EPA reserves the right to verify calibration of test equipment, photograph or videotape the tests, or take independent measurements during the tests.

Refer to Table 3 for a description of the applicable tests, operating configurations, and criteria for the AI fume hood performance tests. Figure 4 provides a flow chart showing the recommended sequence for conducting the AI tests.

**Table 3. "As Installed" Performance Test**

AI Test	Description/Configuration/Condition	Criteria
<b>Inspection</b>		
Laboratory Hood		Acceptable TAB report and must comply with EPA specifications <sup>1</sup> .
Laboratory		
<b>Operating Conditions Tests</b>		
Laboratory Environment Tests	Room Differential Pressure (Doors Closed)	Must comply with EPA design specifications <sup>1</sup> .
	Room Temperature (Doors Closed)	Must comply with EPA design specifications <sup>1</sup> .
Cross-Draft Velocity Test	Vertical 100% and 80% Open	30-second average velocity $\leq$ 30 fpm
	Horizontal Max Center Opening	

**Table 3. “As Installed” Performance Test**

<b>AI Test</b>	<b>Description/Configuration/Condition</b>	<b>Criteria</b>
Face Velocity Test	Vertical 100% Open	Standard Fume Hoods, constant volume <ul style="list-style-type: none"> <li>• Target AFV = 80 fpm (-0/+10 fpm)</li> </ul> Low-Velocity Fume Hoods, VAV systems <ul style="list-style-type: none"> <li>• Target AFV = 60 fpm (-0/+6 fpm)</li> </ul>
	Vertical 80% Open	Standard Fume Hoods, constant volume <ul style="list-style-type: none"> <li>• Target AFV = 100 fpm (-0/+10 fpm)</li> </ul>
	Horizontal Max Openings (Left, Center, and Right)	Standard Fume Hoods <ul style="list-style-type: none"> <li>• Target AFV <math>\geq</math>100 fpm (-0/+10fpm)</li> </ul> Low-Velocity Fume Hoods <ul style="list-style-type: none"> <li>• Target AFV <math>\geq</math>60 fpm (-0/+6 fpm)</li> </ul>
	Vertical Sash 6 in. Open	AFV <300 fpm
Hood Monitor	All sash configurations used for face velocity tests.	Indicated velocity or flow $\leq$ 5% variation from corresponding measured value
Exhaust Flow and Hood Static Pressure Measurement	Vertical Sash 80% Open	<ul style="list-style-type: none"> <li>• Manufacturer’s specified flow <math>\pm</math>5% to achieve EPA AFV criteria</li> <li>• Hood static pressure <math>\leq</math>0.25 in. w.g.</li> </ul>
	Horizontal Sash Max Center Opening	
	Sashes Closed	
VAV Response and Stability Test	Vertical 80% Open	<ul style="list-style-type: none"> <li>• Response Time <math>\leq</math>5 seconds</li> <li>• Flow Stability <math>\leq</math>10% variation</li> </ul>
	Horizontal Max Opening	
<b>Containment Performance Tests</b>		
Airflow Visualization Tests (smoke)	Vertical 100% Open	No visible escape beyond plane of sash
	Vertical 80% Open	
	Horizontal Max Openings (Left, Center, and Right)	
Tracer Gas Containment Tests (Static Mannequin)	Vertical 80% Open <ul style="list-style-type: none"> <li>• Left, Center, Right Test Positions</li> <li>• Tall Mannequin Height, 23 in. BZ</li> <li>• Short Mannequin Height, 18 in. BZ</li> </ul>	<ul style="list-style-type: none"> <li>• Average 5-minute concentration <math>\leq</math>0.1 ppm</li> <li>• Maximum 30-second rolling average <math>\leq</math>0.1 ppm</li> <li>• Peak concentration <math>\leq</math>0.5 ppm</li> </ul>
	Horizontal Left, Center, and Right Max Openings <ul style="list-style-type: none"> <li>• Center Test Position at each Horizontal opening</li> <li>• Tall Mannequin Height 23 in. BZ</li> <li>• Short Mannequin Height 18 in. BZ</li> </ul>	
	Opening Scan <ul style="list-style-type: none"> <li>• Vertical 80% Open</li> <li>• Horizontal Max Left, Center, and Right Openings</li> </ul>	
Sash Movement Effect Test (VAV Tracer Gas Containment Tests )	Vertical 80% Open (Center)	
	Horizontal Max Center Opening	

<sup>1</sup> If EPA specifications are not available, refer to Table 2.

### 4.3 As Used (AU) Performance Tests

The AU performance tests are conducted at least annually by EPA laboratory personnel or a qualified contractor to ensure that the LFH is performing adequately and meeting EPA specifications. Note that any substantive changes or modifications to the air supply or exhaust systems in a laboratory shall require the fume hoods to be subject to AI tests, instead of AU tests. For the proper use of any fume hood, the following conditions apply to AU tests:

1. EPA laboratory personnel or a qualified contractor shall evaluate the integrity of the hood.
2. EPA laboratory personnel or a qualified contractor shall ensure that operating conditions are equivalent to those found during the initial AI tests (i.e., AFV is unchanged, and smoke containment is unchanged).
3. EPA laboratory personnel or a qualified contractor shall calibrate the hood monitor.
4. EPA laboratory personnel or a qualified contractor shall review the work practices of the fume hood operators.

Refer to Table 4 for a description of the applicable tests, operating configurations, and criteria for the AU fume hood performance evaluation. Figure 5 provides a flow chart showing the recommended sequence for conducting the AU tests.

**Table 4. “As Used” Performance Test**

AU Test	Description/Configuration/Condition	Criteria
<b>Inspection</b>		
Laboratory Hood		Must comply with EPA specifications <sup>1</sup> .
Laboratory		
<b>Operating Conditions Tests</b>		
Laboratory Environment Tests	Room Differential Pressure (Doors Closed)	Must comply with EPA design specifications <sup>1</sup> .
	Room Temperature (Doors Closed)	
Cross-Draft Velocity Test	Vertical 100% and 80% Open	30-second average velocity $\leq$ 30 fpm
	Horizontal Max Center Opening	
Face Velocity Test <sup>2</sup>	Vertical 80% Open	Standard Fume Hoods • Target AFV = 100 fpm (-0/+10 fpm) Low-Velocity Fume Hoods • Target AFV = 60 fpm (-0/+6 fpm)
	Horizontal Max. Openings (Left, Center, and Right)	Standard Fume Hoods • Target AFV = 100 fpm (-0/+10 fpm) Low-Velocity Fume Hoods • Target AFV $\geq$ 60 fpm (-0/+6 fpm)
Hood Monitor	All sash configurations used for face velocity tests	Indicated velocity or flow $\leq$ 5% variation from corresponding measured value
Auxiliary Air Velocity Test (if applicable)	Vertical 100% Open	Average Auxiliary Air Velocity $\leq$ 2.5 times the design opening AFV or $\leq$ 70% of the LFH exhaust volume.

**Table 4. “As Used” Performance Test**

<b>AU Test</b>	<b>Description/Configuration/Condition</b>	<b>Criteria</b>
Dynamic VAV Response and Stability Test	Vertical 80% Open	<ul style="list-style-type: none"> <li>• Response time <math>\leq 5</math> seconds</li> <li>• Flow stability <math>\leq 10\%</math> variation</li> </ul>
	Horizontal Max. Opening	
<b>Containment Performance Tests</b>		
Airflow Visualization Tests (smoke)	Vertical 100% Open	No visible escape beyond plane of sash
	Vertical 80% Open	
	Horizontal Max Openings (Left, Center, and Right)	

<sup>1</sup> If EPA specifications are not available, refer to Table 2.

<sup>2</sup> For auxiliary air hoods, the auxiliary air must be turned off or redirected during face velocity tests.

Figure 5. Sequence for Conducting AU Performance Tests

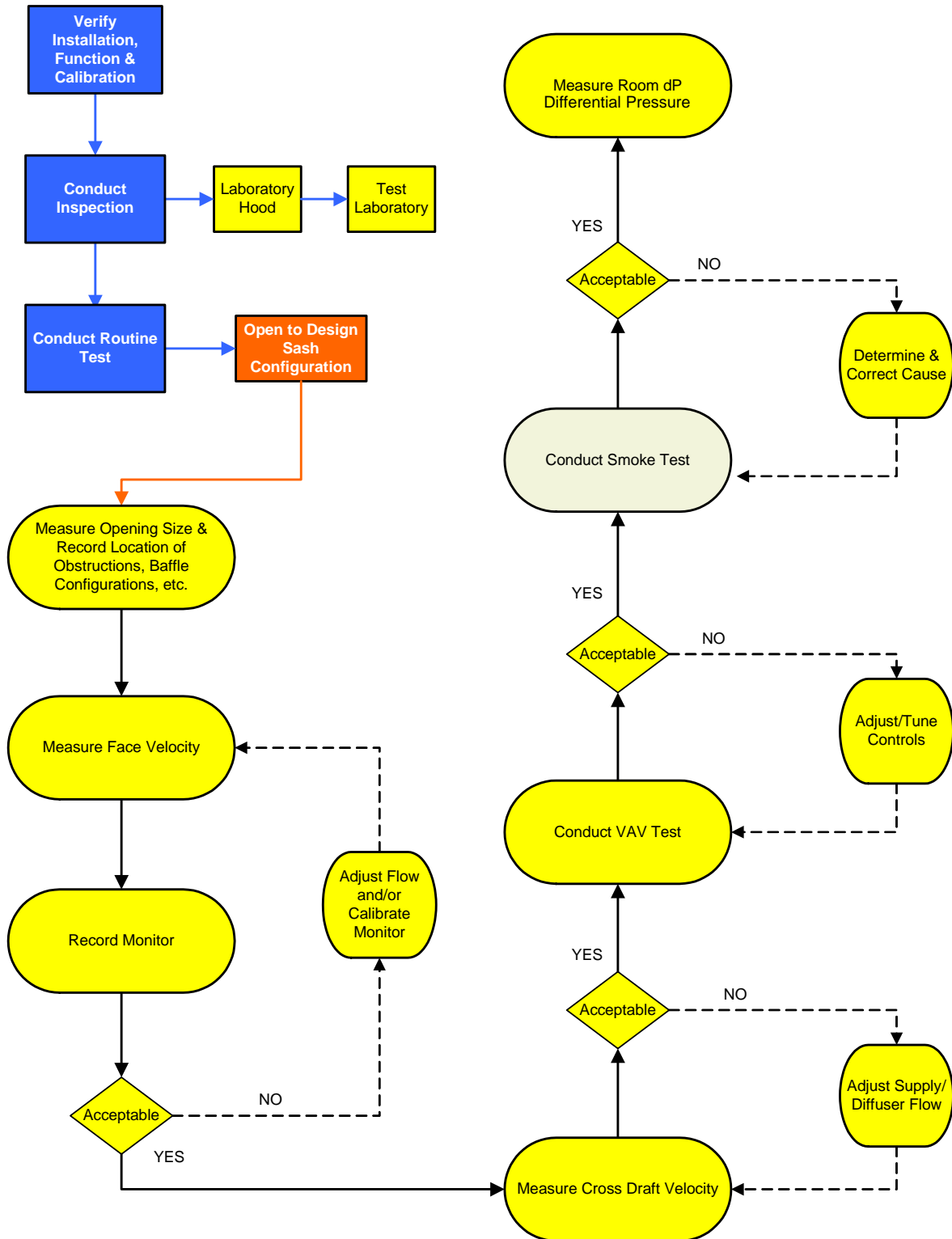



## 5.0 PERFORMANCE TEST PROCEDURES

The results of each test shall be recorded on EPA's performance test data sheets (see Appendix A of this document for test data sheets) or equivalent. The required number of test cycles shall be dependent on the hood type, sash type, baffle design, and specified AFV. All test equipment must comply with the requirements of this standard, and EPA reserves the right to verify calibration of test equipment, photograph or videotape the tests, or take independent measurements before, during, or after the routine tests.

### 5.1 Inspection

The fume hood performance tests begin with inspections of the fume hood, laboratory, and exhaust systems. Figure 6 provides a diagram of a typical bench-top LFH for reference.

**Figure 6. Typical Bench-Top LFH**

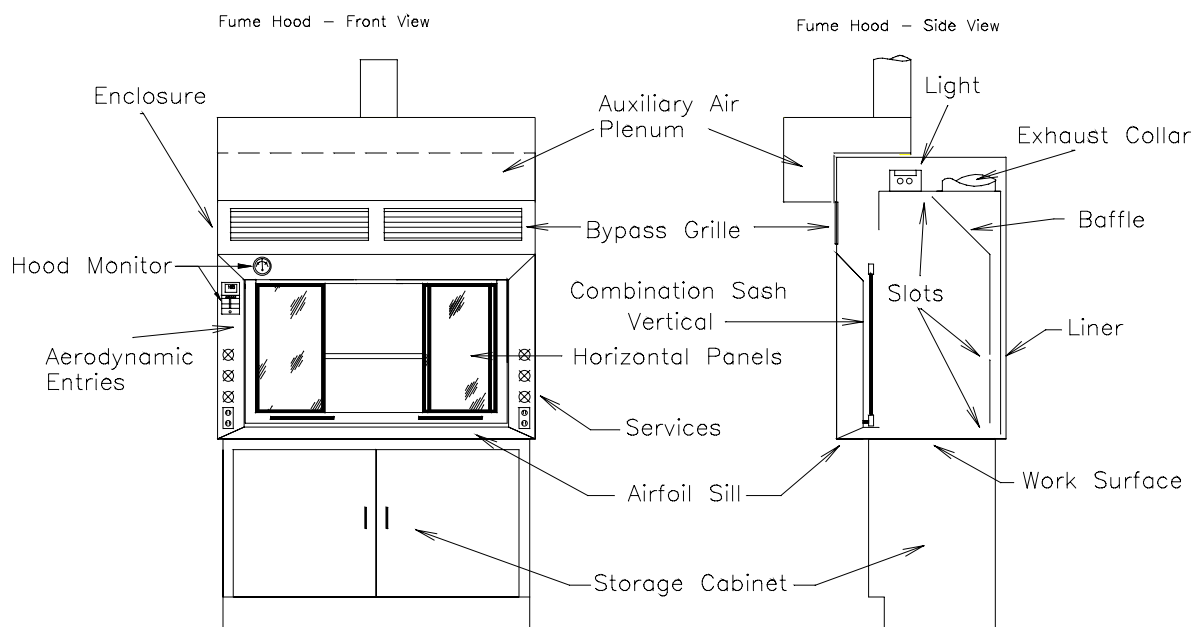

#### 5.1.1 Hood Inspection

1. Record all pertinent hood information to identify the design and type of LFH. Record the name and contact information of the person conducting the test.
2. Test for the proper sash operation. The sash should slide freely in its track without binding through the full open position to its completely closed position.
3. Test and confirm the operation of lights. Evaluate the bulb replacement procedure.
4. Check for the presence and proper installation of the airfoil sill.

5. Record the position of baffle, number of capture slots, and slot widths. If the baffle design enables multiple configurations and slot widths, evaluate a range of positions, and revise the test protocol accordingly. If applicable, confirm proper operation of mechanical baffle actuator.
6. Confirm the connection of exhaust collar to exhaust duct. (If this observation is not possible because hood is equipped with hood enclosing panels, inspect the superstructure for negative or positive leaks.)
7. Check the integrity and cleanliness of the work surface and the hood liner, ensuring there are no cracks, warping, or excessive leakage. Check for a sash sweep behind the sash at the top of the enclosure.
8. Record the type and manufacturer of the monitor. Verify visible and audible alarm operation.

#### 5.1.2 Laboratory Inspection

1. Measure and record the test room (for AM test) or laboratory (for AI test) dimensions. Calculate the room volume.
2. Evaluate the air supply system, and record airflow control settings (for AM test only).
3. If a VAV system is present, record the manufacturer and type of controls.
4. Measure and record test room or laboratory differential pressure across all doors and to ceiling space above the hood.
5. Measure and record test room or laboratory temperature at the center of hood opening, 18 inches in front of the sash plane.
6. Note the number, location, type, and size of air supply fixtures.
7. Make a sketch of the test lab indicating hood, doors, supply diffusers, other exhaust devices, and the location of significant lab furniture.
8. Note possible sources of cross drafts (see Section 5.2.6 and Figure 8 for cross-draft velocity test procedures).

#### 5.1.3 Exhaust System Inspection (only for use with the AM performance test)

1. Evaluate the hood exhaust system, and record airflow control settings.
2. If a VAV system is present, record manufacturer and type of controls.
3. Record hood outlet dimensions and exhaust duct diameter. Make note of any transitions within 10 feet of the hood outlet.

## 5.2 Operating Conditions Tests

The following procedures verify that the fume hood is operating to meet EPA specifications for face velocity, exhaust flow, laboratory supply, VAV or sash movement effect test (SME) response, and VAV stability.

### 5.2.1 Laboratory Environment Tests (Room Differential Pressure and Temperature)

#### 1. Room Differential Pressure

- Close all doors and access openings to the lab. Close the sashes on all hoods.
- While holding the pressure meter on one side of the door, run a length of tubing below the door into the adjacent non-lab space, and record the differential pressure.
- Determine the average room differential pressure from three consecutive measurements.
- Repeat pressure measurements with sashes on all hoods open to the design opening area.

#### 2. Room Temperature

- Close all doors and access openings to the lab. Close the sashes on all hoods.
- While holding the temperature probe near the thermostat, measure and record the room temperature.
- Compare the measured temperature to the temperature reported by the room thermostat.
- Repeat temperature measurements with sashes on all hoods open to the design opening area.

### 5.2.2 Cross-Draft Velocity Test

1. Cross-draft velocities are measured to determine the velocity of room air currents near the hood opening. Refer to Figure 7 for a diagram of a hood and locations for measurement of cross drafts.

**Figure 7. Probe Location and Orientation to Determine Maximum Cross-Draft Velocity Near the Hood Opening**

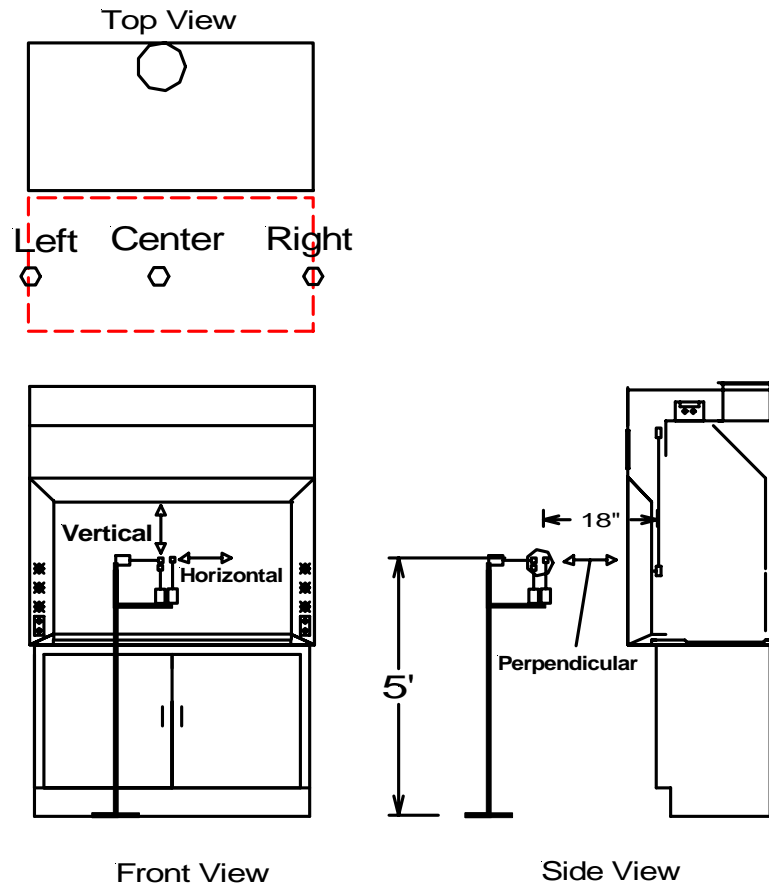

2. Fix the velocity meter probe at 18 inches in front of the hood enclosure and approximately 60 inches above the floor. The probe should be positioned to independently measure the horizontal, vertical, and perpendicular components of velocity at each of the three test locations. The test locations should correspond to the left side, center, and right sides of the hood.
3. Measure the cross-draft velocity with the probe oriented in the horizontal, vertical, and perpendicular directions at each test location. The perpendicular direction is normal to the sash plane.
4. Record the minimum, maximum, and average velocities measured over a period of at least 10 seconds.

### 5.2.3 Face Velocity Test

For all steps of the face velocity test procedure, the hood interior chamber shall be empty for AM and AI tests, except for the required test equipment and components provided with the hood. The AU tests are conducted as found, unless the equipment interferes with the probe.

1. Configure the sash for the appropriate test opening.
2. Measure the sash opening width and height, and calculate the face area in square feet. Be sure to include the area beneath the airfoil sill in the calculation of face area. The sash height is measured from the bench top to the bottom of the sash.
3. Ensure that the exhaust blower is operating, and adjust the flow to achieve the specified target AFV. For low-velocity LFHs at 80 percent or 100 percent open, the AFV shall also be adjusted to 60 fpm (-0 to +10 percent).
4. Divide the opening into equal area grids of no greater than 1 ft<sup>2</sup> (see Table 5 for recommended grid array and Figure 8 for examples of grid patterns).

**Table 5. Face Velocity Traverse Grids for Different Size Openings**

Opening Height -in.	Width—ft							
	≤1 ft	≤2 ft	≤3 ft	≤4 ft	≤5 ft	≤6 ft	≤7 ft	≤8 ft
≤12 in.	1×1	1×2	1×3	1×4	1×5	1×6	1×7	1×8
≤24 in.	2×1	2×2	2×3	2×4	2×5	2×6	2×7	2×8
≤36 in.	3×1	3×2	3×3	3×4	3×5	3×6	3×7	3×8

**Figure 8. Sample Grid Configurations With Fixed Probe at Center of Traverse Grid**

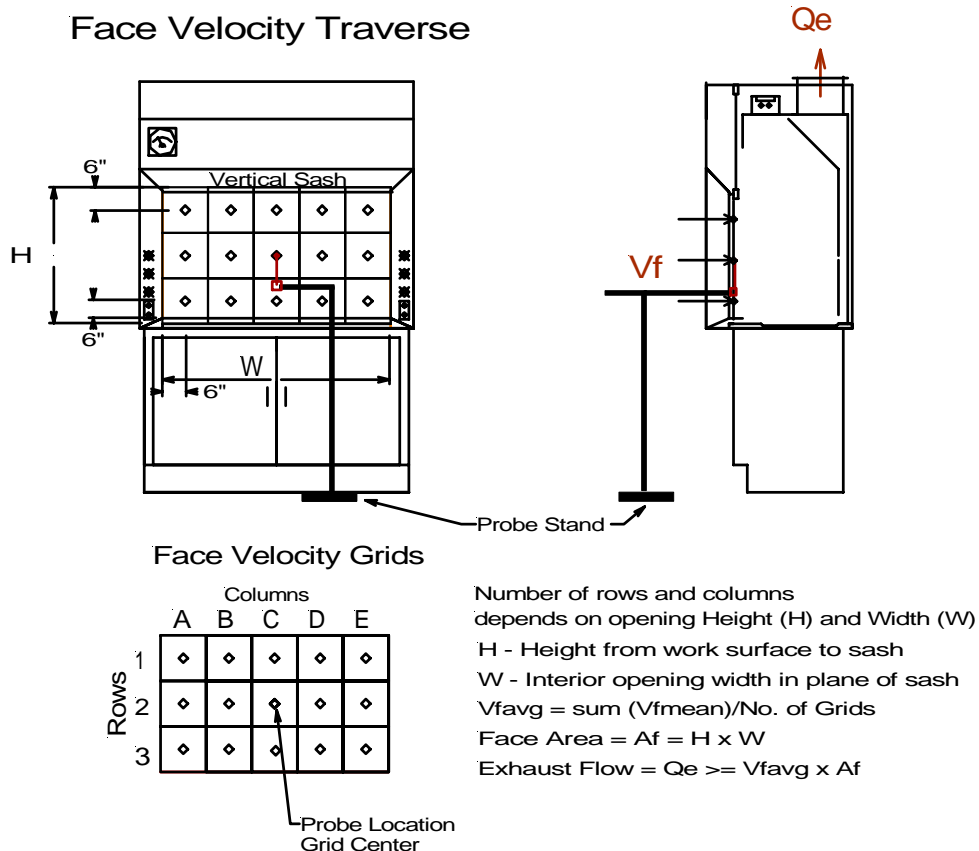

5. Measure velocity readings with a calibrated unidirectional hot-wire anemometer fixed at the center of each grid. Place the probe in the sash plane and stabilized using a ring stand and clamp or equivalent. Ensure the probe is aligned to measure the velocity vector perpendicular to the sash plane. The sash plane is defined as the front of the glass on the outermost sash panel.
6. Measure face velocity readings over a period of at least 10 seconds or 10 readings at each grid location. If the anemometer measures instantaneous point velocities, measure a minimum of 10 readings at each grid location. Be sure to stand to the side of the opening while taking readings to avoid disrupting airflow patterns.
7. Record the mean of 10 readings at each grid location. Unless specifically required by hood design, mean grid velocities not within a tolerance of  $\pm 20$  percent of the target AFV shall require readjustment of the hood airflow and baffle position, or shall be sufficient cause for rejection of the hood.
8. Calculate the average of the mean grid velocities, and record the result as the AFV.
9. Compare the AFV to the face velocity criterion. Velocity measurements shall be repeated at each test configuration as defined herein.

#### 5.2.4 Hood Monitor

1. Record the manufacturer, model, and type of monitor.
2. Record the monitor reading, and note the range of readings while conducting the face velocity traverse.
3. Compare the average monitor reading to the measured AFV.
4. If out of compliance, calibrate the monitor according to the manufacturer's recommended procedure.

#### 5.2.5 Exhaust Flow and Hood Static Pressure Measurements

1. If data is not available from a testing and balancing (TAB) report or has not been collected previously to compare calculated exhaust flow to measured flow, then the exhaust flow shall be measured by conducting a Pitot tube traverse in the exhaust duct connected to the hood in conformance with ASHRAE 41.2, *Standard Methods for Laboratory Air-Flow Measurement*. Calculated flow from the opening area multiplied by the measured face velocity is not acceptable.
2. Measure flow at the Pitot tube traverse at the design sash opening and with the sashes closed in the exhaust duct.
3. Inspect the exhaust ductwork above the hood and locate an accessible run of straight duct of at least seven duct diameters in length. Straight duct runs may be

difficult to locate and shorter runs may increase measurement error. Note on the test report if the Pitot tube traverse is conducted in a less than desirable location.

4. At the downstream end of the straight run of duct, drill two 3/8-inch holes at right angles in the duct. Ensure the holes are plugged after conducting tests.
5. Measure the inside diameter of the duct, and calculate the area of the duct using the equation:

$$A_d = \frac{(D^2 \pi)}{4}$$

where:

$A_d$  = Area  
 $D$  = Diameter  
 $\pi$  = Pi

6. Determine exhaust air temperature, elevation, and barometric pressure to correct for prevailing air density. Ensure measurements are corrected for non-standard conditions. If data requires correction, be sure to record corrected and non-corrected data.
7. Connect static and total pressure ports on the Pitot tube to the manometer using flexible tubing. Insert the Pitot tube probe in each hole and take velocity pressure or velocity readings at the center of annular rings of equal area. A minimum of 10 readings shall be taken across each cross section. The reading shall be taken at distances equal to the duct diameter multiplied by the factors listed in Table 6.

**Table 6. Pitot Traverse Points in a Circular Duct of Known Duct Diameter**

Traverse Point	1	2	3	4	5	6	7	8	9	10
Distance = D ×	0.026	0.082	0.146	0.226	0.342	0.685	0.774	0.854	0.918	0.974

8. If velocity pressure readings were taken in Step 7, convert these readings to velocities. Calculate the sum and average of the velocities. Negative values, if recorded during the traverse, are added in at zero value but are counted in the number of sample locations for calculation of the average. A negative value indicates non-uniform duct velocity and an inaccurate traverse. Calculated flow from inaccurate traverses should be noted.
9. Record the average duct velocity. Multiply the duct area by the duct velocity to obtain the resultant exhaust flow. Record exhaust flow.
10. Measure and record the hood static pressure at the outlet collar or traverse test location if applicable. The hood static pressure should be measured as close to the hood as possible, given any turbulence or an inability to penetrate the duct at the collar. Record the location of hood static pressure measurement.

### 5.2.6 Auxiliary Air Velocity Tests

Auxiliary air fume hoods require special test procedures for determining the average face velocity and downflow auxiliary air velocity. The AFV is determined using the same method described above, but the auxiliary air must be turned off or redirected by blocking the outlet of the auxiliary air plenum. Following determination of the AFV while blocking the auxiliary air plenum, the following method can be used to determine the downflow velocity.

1. Ensure the auxiliary air supply is operating and the plenum outlet is not obstructed.
2. Raise the sash to the full open position.
3. Divide the outlet into equal area grids of no more than 12 inches per side.
4. Measure the vertical component of velocity at the center of each grid with the probe mounted approximately 6 inches below the plenum outlet.
5. Record the velocities for a minimum of 10 seconds or 10 readings at each grid location.
6. Determine the average auxiliary air velocity from the mean grid velocities

### 5.2.7 Dynamic VAV Response and Stability Tests

This test applies to laboratory hood systems equipped with VAV controls that modulate flow in response to sash movement. Flow response is determined by measurement of exhaust flow (Method A) or by measurement of LFH slot velocity (Method B), see Figure 9. Measurements are recorded at a rate of one reading per second using a data logger while opening and closing the LFH sashes. Each 5-minute test consists of three cycles of opening and closing the sash where the sash is closed for 30 seconds and open for 60 seconds during each cycle. The results are analyzed to determine the speed of response, time to steady state, and repeatability of flow response.

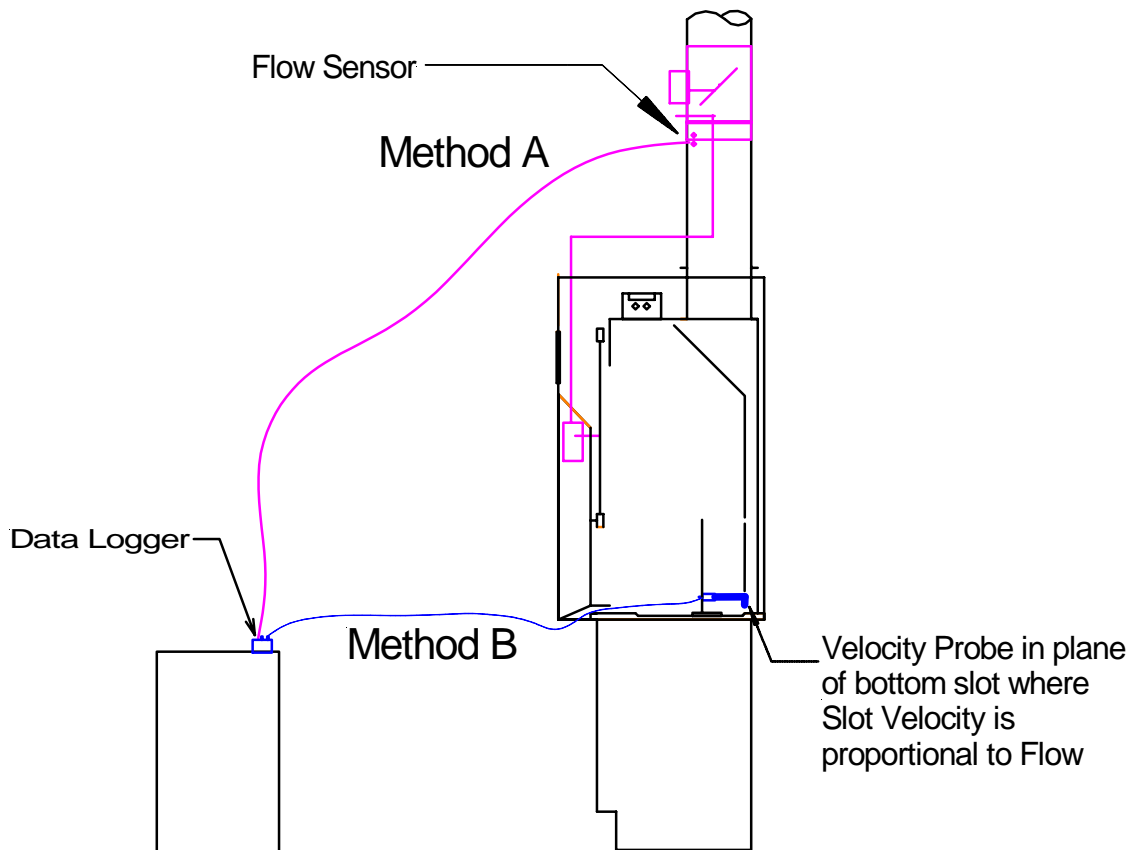

**Figure 9. Setup for VAV Response and Stability Tests**

1. Position sensor in a location with stable flow (turbulent fluctuations with variation <10 percent) (see Figure 9 for a diagram of test setup methods).
  - Method A: Use a flow sensor or locate a velocity meter in the centerline of the exhaust duct.
  - Method B: Mount the velocity probe in a secure stand with the probe located in the plane of the bottom baffle slot.
2. Close all sashes and record LFH monitor reading.
3. Begin recording flow or equivalent indicator at a rate of one reading per second using a data logger.
4. After 30 seconds, open the sash from the closed position to the design opening area at a rate of approximately 1.5 feet per second (ft/sec). Note and record with the data logger the time corresponding to the beginning of sash movement.
5. After 60 seconds close the sash at a rate of approximately 1.5 ft/sec.

6. Determine the speed of response in seconds (VAV response time) following the start of sash movement until the flow reaches 90 percent of the final steady state flow.
7. Repeat Steps 4 through 6 two more times to obtain a total of three sash opening/closing cycles. Each cycle shall have the sash closed for 30 seconds and open for 60 seconds.
8. With the data logger results, plot the VAV flow response, and record results.

### 5.3 Containment Performance Tests

The following procedures verify that the fume hood provides acceptable containment according to EPA specifications for smoke and tracer gas containment.

#### 5.3.1 Airflow Visualization Tests (smoke)

Verify the hood exhaust blower is operating. For all steps of the visualization test procedure, the hood interior chamber shall be empty, except for the required test equipment. For the local visualization challenge, conduct the smoke tests with the vertical and horizontal sashes fully open and again with the sash at the design opening height (usually 80 percent open).

The visual test of containment using smoke shall be conducted in the absence of the mannequin. Results are reported as a qualitative judgment of airflow distribution according to the ratings described in Table 7. If this test result is a rating other than fair or good, this shall be sufficient cause to reject the LFH.

**Table 7. Rating of Observed Airflow Patterns**

<b>Rating</b>	<b>Description</b>
FAIL	<ul style="list-style-type: none"> <li>• Smoke was visually observed escaping outside the plane of the sash.</li> </ul>
POOR (Low Pass)	<ul style="list-style-type: none"> <li>• Reverse flow of smoke is evident within 6 inches of opening</li> <li>• Lazy flow into hood along openings</li> <li>• Slow capture and clearance (greater than 1 minute)</li> <li>• Observed potential for escape</li> </ul>
FAIR (Pass)	<ul style="list-style-type: none"> <li>• Some reverse flow in hood not within 6 inches of sash plane</li> <li>• Limited turbulent vortex flow inside hood</li> <li>• Smoke is captured and clears readily (less than 1 minute)</li> <li>• No visible escape</li> </ul>
GOOD (High Pass)	<ul style="list-style-type: none"> <li>• Good capture and quick clearance</li> <li>• Limited vortex flow inside hood</li> <li>• No reverse flow regions</li> <li>• No visible escape</li> </ul>

1. Low Volume Visualization Challenge
  - While holding a smoke tube, smoke stick, or smoke generator in the hood, begin generation of the smoke in accordance with the manufacturer's

recommendations<sup>1</sup>. Generate the smoke along the openings and along the airfoil sill. Observe and record airflow patterns. The smoke should flow smoothly into the hood.

- Run the smoke slowly beneath the airfoil sill and observe the flow patterns. The smoke should be exhausted smoothly across the work surface and not be entrained in the vortex at the top of the hood.
- Discharge a stream of smoke or swab the smoke stick along the work surface and interior walls of the hood at 6 inches inside the sash plane. Observe and record airflow patterns, capture by the slots and exhaust. Look for areas of lazy flow, reverse flow, and vortex development in top of hood. Define air movement towards the opening of the hood as reverse flow.
- If any smoke is observed escaping the hood opening, stop generation and correct problems immediately. Use caution to avoid exposure to or inhalation of smoke sources.

## 2. High Volume Visualization Challenge

- Using a suitable source of smoke for visual challenge, release a large volume on the work surface and in the top of the hood approximately 6 inches behind the plane of the sash. Ensure that the smoke source does not have high-velocity components in the direction of the opening. Observe and record airflow patterns, capture, and time of clearance after generation has ceased. Tests shall be halted if any smoke is observed escaping the hood opening.
- Refer to Table 7 for evaluation and rating of hood airflow patterns.

### 5.3.2 Tracer Gas Containment Tests (static mannequin)

Unless otherwise specified, the tracer gas test procedure and test requirements shall follow the methods described in the ANSI/ASHRAE 110, *Method of Testing Performance of Laboratory Fume Hoods*. Tracer gas tests during AM performance testing shall include at least two series of tests at two mannequin heights for each sash configuration (minimum of two vertical sash heights - sash 80 percent open and sash 100 percent open). See Table 8 for required test configurations. Additional series of tracer gas tests may also be required to evaluate all possible baffle configurations and effects of flow changes. All low-velocity LFH tracer gas tests during AM performance tests shall include at least one series of tests at the design sash opening with one mannequin height. In addition, EPA may require tracer gas testing for any fume hoods when deemed necessary.

---

<sup>1</sup> Note that two sources of smoke are required – low volume and high volume. A smoke bomb is only appropriate for the high volume test. Aerosol cans of smoke are not acceptable for EPA performance testing.

The LFH shall not be approved for use at flow rates or sash positions that do not meet EPA performance criteria. Failure to meet the performance requirements during performance tests shall be sufficient cause to reject the hood.

1. **Mannequin Height.** The mannequin heights shall be based on the hood type and sash type. For bench-top hoods, the mannequin height is based on the height of the breathing zone (BZ) above the work surface where the BZ correlates to the center of the mannequin's lips. The corresponding mannequin height shall be maintained for all tracer gas tests. For distillation hoods and floor-mounted hoods, the height of the mannequin is based on the distance between the top of the mannequin's head and the floor. Where appropriate, the fume hood will be tested at two mannequin heights during AM and one mannequin height during AI performance tests. Refer to Table 8 for specified mannequin heights at each hood type, sash configuration, and test type.

**Table 8. Mannequin Heights for Tracer Gas Tests of Different Fume Hood Types**

Hood Type	Sash Type	Tracer Gas Test <sup>1</sup>	Mannequin Height—in.	BZ Height—in.	AM	AI
Bench-Top Hood	Vertical	1	n/a <sup>2</sup>	23	X	X
		2	n/a	18	X	
Bench-Top Hood	Horizontal	1	n/a <sup>2</sup>	23	X	X
		2	n/a	18	X	
Distillation Hood	Multi-Vertical	1	67	n/a	X	X
		2	48	n/a	X	
Floor-Mounted	Multi-Vertical	1	67	n/a	X	X
		2	48	n/a	X	
Floor-Mounted	Horizontal	1	67	n/a	X	X
		2	48	n/a	X	

<sup>1</sup> Perform Tracer Gas Test for each sash configuration (minimum of two vertical sash heights - sash 80 percent open and sash 100 percent open) for each mannequin/breathing zone height.

<sup>2</sup> Mannequin heights can be derived from the breathing zone and bench top heights.

2. **Ejector Location.** For all LFHs, the ejector shall be located 6 inches behind the plane of the sash. The plane of sash is the vertical plane corresponding to the front of the glass panel on the forward most sash panel. For bench-top hoods or fume hoods having interior tables, the ejector shall be placed on the work surface (table top) and located in front of the mannequin at each test position. For distillation and floor-mounted hoods that are not equipped with internal tables, the ejector shall be placed on the lower surface or bottom of the hood (see Figures 10, 11, and 12). The ejector flow rate shall be 4 liters per minute of at least 98 percent pure sulfur hexafluoride.

**Figure 10. Placement of Mannequin and Tracer Gas Ejector for Bench-Top LFHs**

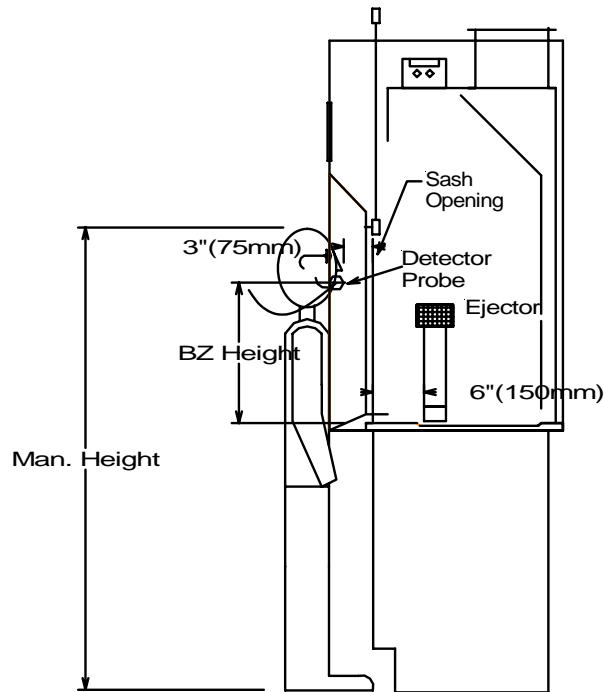

**Figure 11. Placement of Mannequin and Tracer Gas Ejector for Floor-Mounted (Walk-in) LFHs**  
 (The tracer gas ejector is raised to 36-inch height when a table is located in the LFH.)

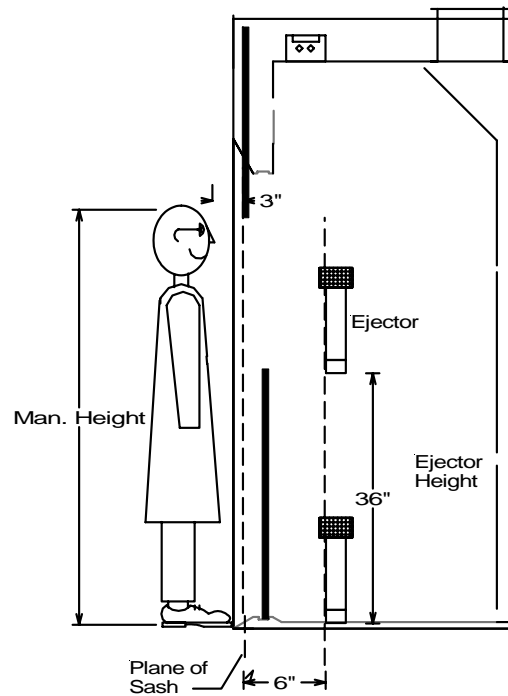

**Figure 12. Placement of Mannequin and Tracer Gas Ejector for Distillation LFHs Equipped With Double Vertical Sliding Sashes**

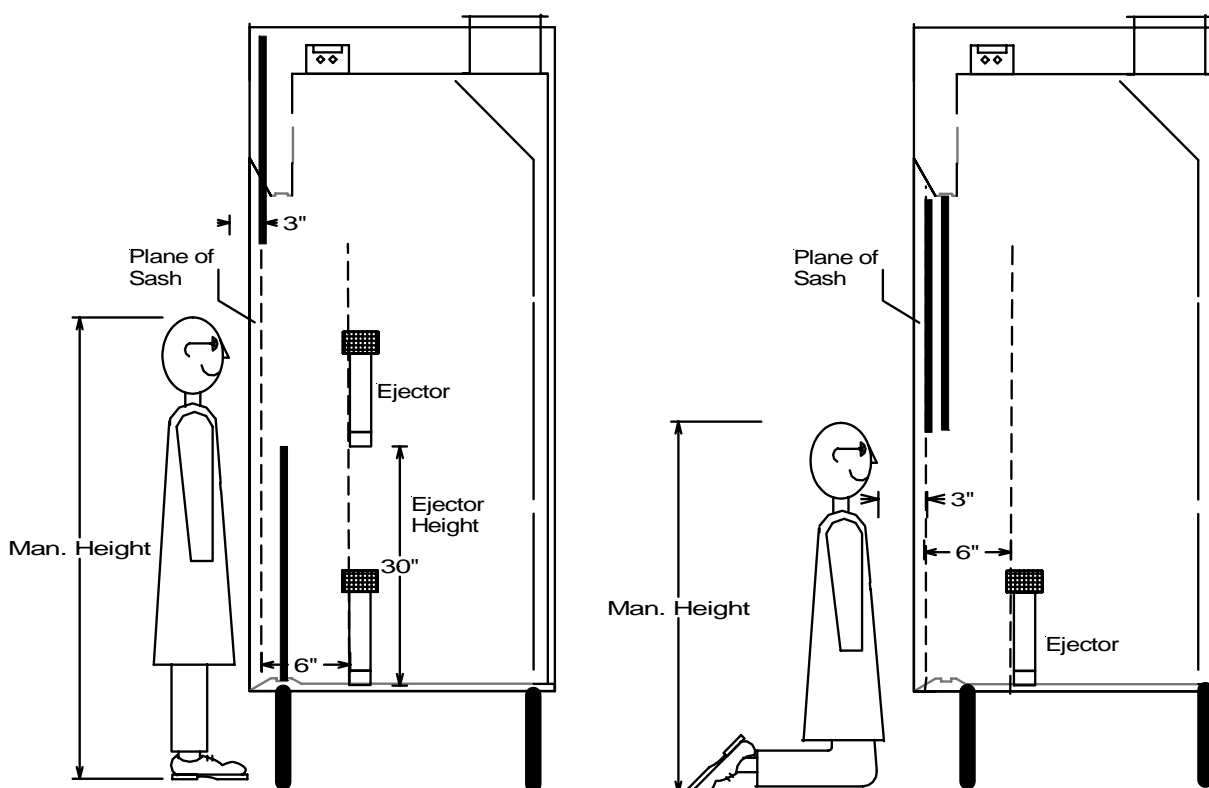

3. Tracer Gas - Opening Scan. With the mannequin removed from the face of the hood and the block valve open to the ejector, the periphery of the hood openings shall be traversed with the probe with the sash fully open. While standing away from the face of the hood, the probe shall be held 1 inch (25 mm) away from the edge of the hood opening and moved slowly around each opening at a rate of no more than 3 inches (75 mm) per second. The maximum concentration and location observed during the traverse shall be recorded. Stand to the side during measurement to affect flow as little as possible.

### 5.3.3 Sash Movement Effect (SME or VAV Tracer Gas Containment Test)

The sash movement effect (SME or VAV tracer gas containment test) is conducted to determine the potential for escape from the hood following movement of the sash from closed to the design opening height (typically 80 percent open). This method is applicable to both constant air volume (CAV) and VAV hood systems but it is only required for VAV hood systems (see Tables 2, 3, and 6 for pass or fail criteria).

1. Using the same mannequin and tracer gas ejector arrangement as the tracer gas tests, locate the mannequin and ejector at the center position of the hood opening.
2. Close the sash or sashes.

3. Begin generation of gas at 4 liters per minute.
4. After 30 seconds, begin recording tracer gas concentrations at a rate of one sample per second using a data logger.
5. After 30 seconds, open the sash from the closed position to the design opening height at a rate of approximately 1.5 ft/sec. Note the time corresponding to the beginning of sash movement.
6. After 60 seconds, close the sash at a rate of approximately 1.5 ft/sec.
7. Repeat Steps 5 and 6 two more times to obtain a total of three sash opening/closing cycles.
8. Close sash for 30 seconds.
9. Calculate the average tracer gas concentration for the 5-minute test. Note the maximum 30-second rolling average associated with each opening and closing of the sash.

## 6.0 AM AND AI FUME HOOD PERFORMANCE CRITERIA

Test	Criteria	Notes
Cross-Draft Test	<ul style="list-style-type: none"> <li>Vcd ≤30 fpm</li> <li>Max ≤50 fpm or 50% of AFV</li> </ul>	<ul style="list-style-type: none"> <li>Design sash opening.</li> </ul>
Face Velocity— Maximum Sash Opening	<ul style="list-style-type: none"> <li>Vfavg = 80 fpm</li> <li>Vfmin ≥80 fpm</li> <li>Vfmax ≤90 fpm</li> </ul>	<ul style="list-style-type: none"> <li>VAV hoods may have 100 fpm face velocity at 100% sash full open.</li> </ul>
Face Velocity— Design Sash Opening	<ul style="list-style-type: none"> <li>Vfavg = 100 fpm</li> <li>Vfmin ≥100 fpm</li> <li>Vfmax ≤110 fpm</li> </ul>	<ul style="list-style-type: none"> <li>Mechanical sash stop installed at 80% of sash opening.</li> <li>Monitor must indicate within 5% of actual face velocity.</li> </ul>
Face Velocity— Maximum Sash Opening Low-Velocity Fume Hoods	<ul style="list-style-type: none"> <li>Vfavg ≥60 fpm</li> <li>Vfmin ≥60 fpm</li> <li>Vfmax ≤66 fpm</li> </ul>	<ul style="list-style-type: none"> <li>Monitor must indicate within 5% or 5 fpm of actual face velocity.</li> <li>Criteria applicable to low-velocity fume hood or equivalent design.</li> </ul>
Face Velocity—6-in. Opening	<ul style="list-style-type: none"> <li>Vfavg &lt;300 fpm for CAV hoods</li> <li>Vfavg ≥100 fpm for VAV hoods</li> </ul>	<ul style="list-style-type: none"> <li>The maximum velocity is for practical reasons and tests bypass effectiveness.</li> </ul>
Exhaust Flow and Hood Static Pressure	<ul style="list-style-type: none"> <li>Flow required to achieve AFV.</li> <li>Hood static pressure shall be less than 0.25 in. water gage at design sash opening and 100 fpm face velocity.</li> </ul>	<ul style="list-style-type: none"> <li>There may be some concession for large distillation and floor mounted hoods.</li> </ul>
Dynamic Response and Stability Test	<p>VAV Response Test:</p> <ul style="list-style-type: none"> <li>Time required for VAV to modulate flow with sash closed to 90% of steady state flow with sash at design opening must be less than or equal to 5 seconds.</li> <li>The time for VAV to modulate flow shall not exceed 5 seconds.</li> </ul>	<ul style="list-style-type: none"> <li>The response time includes the time required to raise the sash.</li> </ul>
	<p>VAV Stability Test:</p> <ul style="list-style-type: none"> <li>The variation determined by the coefficient of variation shall be less than 10% of the steady state flow with the sash closed or with the sash at the design sash opening.</li> </ul>	<ul style="list-style-type: none"> <li>The coefficient of variation is calculated as:  <math display="block">\%COV = 100 \times (3 \times \text{standard deviation}) / \text{average steady state flow}</math> </li> </ul>
Airflow Visualization Tests (smoke)	<ul style="list-style-type: none"> <li>Smoke observed beyond plane of sash when generated 6 inches inside the plane of the sash fails the test.</li> <li>Hood must have a smoke rating of Fair or Good.</li> <li>A Rating of Low Pass or Poor may constitute failure of the hood.</li> </ul>	<ul style="list-style-type: none"> <li>Smoke should not be discharged at high velocity and directed towards the opening.</li> <li>VAV hoods should undergo an additional challenge by raising and lowering the sash.</li> </ul>
Tracer Gas Containment Tests (static mannequin and Sash Movement Effect Test (VAV Tracer Gas Containment Tests)	<ul style="list-style-type: none"> <li>The maximum 5-minute average BZ concentration must be ≤0.05 ppm for AM and ≤0.10 ppm for AI performance tests.</li> <li>The maximum 30-second rolling average shall be less than 0.1 ppm. Rolling average is the average of any consecutive 30-second period.</li> <li>The peak BZ Concentration shall not exceed 0.5 ppm.</li> </ul>	<ul style="list-style-type: none"> <li>The maximum 5-minute average concentration applies to any test configuration or mannequin position.</li> <li>30-second rolling averages shall be calculated during opening scan and sash movement tests. The 30-second rolling average negates instrument detection methods and replaces peak escape.</li> </ul>

Definitions: Vcd – Cross-draft velocity, Vfavg – Average face velocity, Vfmin – Minimum face velocity, Vfmax – Maximum face velocity, COV – Coefficient of variation.



**APPENDIX A – AM AND AI TEST FORMS AND DATA SHEETS**

# Hood, Lab, and System Inspection Form

Test Date: \_\_\_\_\_

Type of Test:  As Manufactured Performance Test  As Installed Performance Test

Lab Hood Manufacturer: \_\_\_\_\_

Address: \_\_\_\_\_ Tel: \_\_\_\_\_

\_\_\_\_\_ Web: \_\_\_\_\_

Hood ID: _____	Hood Type: _____
Hood Model: _____	
Serial Number: _____	Size: _____ ft

## Hood Design Features:

Super Structure:	Material of Construction: _____	Exterior Dimensions	Height: _____ in. Width: _____ in. Depth: _____ in.
Sash:	<input type="checkbox"/> Vertical <input type="checkbox"/> Horizontal <input type="checkbox"/> Combination <input type="checkbox"/> Hinged <input type="checkbox"/> None/Fixed <input type="checkbox"/> Automated Sash Closure Device	Number of Sashes: _____ Number of Sash Panels: _____ Panel Widths: _____ in. Vertical Opening: Max. Opening Height: _____ in. Max. Opening Width: _____ in. Horizontal Opening: Max. Opening Height: _____ in. Max. Opening Width: _____ in.	Baffle: <input type="checkbox"/> Adjustable Internal <input type="checkbox"/> Adjustable External <input type="checkbox"/> Automatic Adjustable <input type="checkbox"/> Fixed <input type="checkbox"/> None
Sash Stop:	<input type="checkbox"/> Yes <input type="checkbox"/> No	Height: _____ in.	Number of Slots: _____
Airfoil Sill:	<input type="checkbox"/> Yes <input type="checkbox"/> No	Liner Material: _____	
Bypass Grille:	<input type="checkbox"/> Yes <input type="checkbox"/> No <input type="checkbox"/> Restricted	Recessed Work Surface: <input type="checkbox"/> Yes <input type="checkbox"/> No	
Light Type:	_____	Interior Height: _____ in.	
External Access to Lights:	<input type="checkbox"/> Yes <input type="checkbox"/> No	Interior Depth (Sash Plane to Baffle): _____ in.	
		Interior Work Surface Area: _____ ft <sup>2</sup>	
Services:	_____		
Auxiliary Air Supply:	<input type="checkbox"/> Yes <input type="checkbox"/> No	Supply Outlet Dimensions: Width: _____ in. Depth: _____ in.	
Mechanical Air Supply:	<input type="checkbox"/> Yes <input type="checkbox"/> No	Description: _____	
Additional Comments: _____			

**Hood Monitor Information:**

Factory Installed:  Yes  No

Manufacturer: \_\_\_\_\_ Model: \_\_\_\_\_

Type:  Velocity  Pressure  Flow  Other—Describe: \_\_\_\_\_

Display Units: \_\_\_\_\_ Stated Accuracy/Precision: \_\_\_\_\_

Alarm:  Visual  Audible

**Lab Information:**

Room Dimensions: Length: \_\_\_\_\_ft Width: \_\_\_\_\_ft Height: \_\_\_\_\_ft

Room Volume: \_\_\_\_\_ft<sup>3</sup>

# of Diffusers/Grilles: \_\_\_\_\_

Diffuser Size: Length: \_\_\_\_\_in. Width: \_\_\_\_\_in. Outlet Area: \_\_\_\_\_ft<sup>2</sup>

Supply Diffuser/Grille Type: \_\_\_\_\_

Supply Diffuser Manufacturer: \_\_\_\_\_

Test Room Temperature: \_\_\_\_\_°F **Test Start Time:** \_\_\_\_\_

\_\_\_\_\_°F **Test End Time:** \_\_\_\_\_

Comments:

**Sketch:**

**Exhaust System Information:**

System ID:	_____		
Exhaust Type:	<input type="checkbox"/> VAV <input type="checkbox"/> CAV <input type="checkbox"/> Other	Exhaust Configuration:	<input type="checkbox"/> Single Hood—Single Fan <input type="checkbox"/> Single Hood—Multiple Fan <input type="checkbox"/> Multiple Hood—Single Fan <input type="checkbox"/> Multiple Hood—Multiple Fan <input type="checkbox"/> No Exhaust
Hood Duct Diameter:	_____in.	Flow Monitor:	<input type="checkbox"/>
Duct Material:	_____	Monitor Type:	_____
Filtration:	Yes <input type="checkbox"/> No <input type="checkbox"/>	Damper:	<input type="checkbox"/>
Filtration Type:	_____		
VAV Control Type:	_____		
VAV Manufacturer:	_____		

# Laboratory Hood Performance Test Results

Type of Test:             As Manufactured Performance Test     As Installed Performance Test

Hood Model: \_\_\_\_\_ Size: \_\_\_\_\_ Type: \_\_\_\_\_

Name of Person Conducting Test: \_\_\_\_\_ Test Date: \_\_\_\_\_

## Test Configuration 1 (i.e., Vertical Sash Open 80%)

**Sash Configuration:** \_\_\_\_\_

Opening Dimensions:      Width: \_\_\_\_\_ in.      Height: \_\_\_\_\_ in.      Area: \_\_\_\_\_ ft<sup>2</sup>

Additional Area: \_\_\_\_\_ ft<sup>2</sup>      Total Opening Area: \_\_\_\_\_ ft<sup>2</sup>

Baffle/Slot Configuration: \_\_\_\_\_

Comments: \_\_\_\_\_

\_\_\_\_\_

## Lab Environment Tests

	<u>Design Sash Opening</u>	<u>Sash Closed</u>
Room Differential Pressure:	_____ in.H <sub>2</sub> O	_____ in.H <sub>2</sub> O
Room Temperature:	_____ °F	_____ °F

## Cross-Draft Velocity Test Results:

	Horizontal			Vertical			Perpendicular		
	Left	Center	Right	Left	Center	Right	Left	Center	Right
Min. fpm									
Max. fpm									
Avg. fpm									

**Face Velocity Traverse Test:**

	Col. 1	Col. 2	Col. 3	Col. 4	Col. 5	Col. 6	Col. 7	Col. 8	Col. 9	Col. 10	Col. 11	Col. 12	
Row 1													Avg. Velocity: _____ fpm
Row 2													Min. Velocity: _____ fpm
Row 3													Max. Velocity: _____ fpm
Row 4													Exhaust Flow: _____ cfm
Row 5													
Row 6													Monitor: _____
Row 7													Monitor
Row 8													(sash closed): _____
Row 9													
Row 10													

**Exhaust Flow and Hood Static Pressure measurements:**

Room Volume—ft<sup>3</sup>: \_\_\_\_\_ ft<sup>3</sup> (from Lab Information, Sheet A-3)

	<u>Design Sash Opening</u>	<u>Sash Closed</u>
Hood Exhaust Flow:	_____ cfm	_____ cfm
Hood Static Pressure:	_____ in.H <sub>2</sub> O	_____ in.H <sub>2</sub> O
Lab Supply Flow:	_____ cfm	_____ cfm
Lab Pressure:	_____ in.H <sub>2</sub> O	_____ in.H <sub>2</sub> O
Total Lab Exhaust Flow:	_____ cfm	_____ cfm
Lab Air Changes per Hour:	_____ ACH	_____ ACH

**Auxiliary—Downflow Velocity Traverse Test (if applicable):**

	Col. 1	Col. 2	Col. 3	Col. 4	Col. 5	Col. 6	Col. 7	Col. 8	Col. 9	Col. 10	Col. 11	Col. 12	
Row 1													Avg. Velocity: _____ fpm
Row 2													Min. Velocity: _____ fpm
Row 3													Max. Velocity: _____ fpm
Row 3													Supply Flow: _____ cfm

**Dynamic VAV Response and Stability Tests:**

(See additional notes under VAV Laboratory Hood Test Form, page A-15)

VAV Response Time: \_\_\_\_\_ sec.

VAV Stability Steady State Flow/Velocity Variation Percentage: \_\_\_\_\_ %

**Airflow Visualization Tests (Smoke) Results:**

<b>Low Volume Rating:</b>	<input type="checkbox"/> Fail <input type="checkbox"/> Low Pass/Poor <input type="checkbox"/> Pass/Fair <input type="checkbox"/> High Pass/Good <input type="checkbox"/> N/A
Comments:	
<b>High Volume Rating:</b>	<input type="checkbox"/> Fail <input type="checkbox"/> Low Pass/Poor <input type="checkbox"/> Pass/Fair <input type="checkbox"/> High Pass/Good <input type="checkbox"/> N/A
<b>Approximate Clearance Time:</b>	<input type="checkbox"/> Fail (>2 min.) <input type="checkbox"/> Slow (1–2 min.) <input type="checkbox"/> Fair (30 sec.–1 min.) <input type="checkbox"/> Good (<30 sec.)
Comments:	

**Tracer Gas Containment Test Results:**

<b>Test Series 1</b>		Mannequin Height: _____ in.			
Ejector Location: _____		Breathing Zone Height: _____ in. (23 in.)			
<b>Position</b>	<b>1 Left</b>	<b>2 Center</b>	<b>3 Right</b>	<b>Pos. Control Level</b>	<b>Opening Scan</b>
Avg.—ppm				Max. Avg.: _____ ppm	Max.: _____ ppm
Min.—ppm				Peak: _____ ppm	<b>Grid Location:</b>
Max.—ppm				Rolling Avg.: _____ ppm	

<b>Test Series 1A—SME (VAV Tracer Gas Containment Tests)</b>		
<b>Position</b>	<b>2 Center</b>	<b>Pos. Control Level</b>
Avg.—ppm		Avg.: _____ ppm
Min.—ppm		Peak: _____ ppm
Max.—ppm		Rolling Avg.: _____ ppm

<b>Test Series 2</b>		Mannequin Height: _____ in.		
Ejector Location: _____		Breathing Zone Height: _____ in. (18 in.)		
<b>Position</b>	<b>1 Left</b>	<b>2 Center</b>	<b>3 Right</b>	<b>Pos. Control Level</b>
Avg.—ppm				Max. Avg.: _____ ppm
Min.—ppm				Peak: _____ ppm
Max.—ppm				Rolling Avg.: _____ ppm

**Test Configuration 2 (i.e., Vertical Sash Open 100%)**

<b>Sash Configuration:</b>	_____		
Opening Dimensions:	Width: ____ in.	Height: ____ in.	Area: ____ ft <sup>2</sup>
	Additional Area: ____ ft <sup>2</sup>	Total Opening Area: ____ ft <sup>2</sup>	
Baffle/Slot Configuration:	_____		
Comments:	_____		

**Face Velocity Traverse Test:**

	Col. 1	Col. 2	Col. 3	Col. 4	Col. 5	Col. 6	Col. 7	Col. 8	Col. 9	Col. 10	Col. 11	Col. 12	
Row 1													Avg. Velocity: ____ fpm
Row 2													Min. Velocity: ____ fpm
Row 3													Max. Velocity: ____ fpm
Row 4													Exhaust Flow: ____ cfm
Row 5													
Row 6													Monitor: _____
Row 7													Monitor
Row 8													(sash closed): _____
Row 9													
Row 10													
Row 11													
Row 12													



**Auxiliary—Downflow Velocity Traverse Test:**

	Col. 1	Col. 2	Col. 3	Col. 4	Col. 5	Col. 6	Col. 7	Col. 8	Col. 9	Col. 10	Col. 11	Col. 12	Avg. Velocity: _____ fpm
Row 1													Min. Velocity: _____ fpm
Row 2													Max. Velocity: _____ fpm
Row 3													Supply Flow: _____ cfm

**Airflow Visualization Tests (smoke) Results:**

<b>Low Volume Rating:</b>	<input type="checkbox"/> Fail	<input type="checkbox"/> Low Pass/Poor	<input type="checkbox"/> Pass/Fair	<input type="checkbox"/> High Pass/Good	<input type="checkbox"/> N/A
Comments:					
<b>High Volume Rating:</b>	<input type="checkbox"/> Fail	<input type="checkbox"/> Low Pass/Poor	<input type="checkbox"/> Pass/Fair	<input type="checkbox"/> High Pass/Good	<input type="checkbox"/> N/A
<b>Approximate Clearance Time:</b>	<input type="checkbox"/> Fail (>2 min.)	<input type="checkbox"/> Slow (1–2 min.)	<input type="checkbox"/> Fair (30 sec.–1 min.)	<input type="checkbox"/> Good (<30 sec.)	
Comments:					

**Tracer Gas Containment Test Results:**

<b>Test Series 1</b>		Mannequin Height: _____ in.			
Ejector Location:		Breathing Zone Height: _____ in. (23 in.)			
<b>Position</b>	<b>1 Left</b>	<b>2 Center</b>	<b>3 Right</b>	<b>Pos. Control Level</b>	<b>Opening Scan</b>
Avg.—ppm				Max. Avg.: _____ ppm	<b>Max.: _____ ppm</b>
Min.—ppm				Peak: _____ ppm	<b>Grid Location:</b>
Max.—ppm				Rolling Avg.: _____ ppm	

<b>Test Series 2</b>		Mannequin Height: _____ in.			
Ejector Location:		Breathing Zone Height: _____ in. (18 in.)			
<b>Position</b>	<b>1 Left</b>	<b>2 Center</b>	<b>3 Right</b>	<b>Pos. Control Level</b>	
Avg.—ppm				Max. Avg.: _____ ppm	
Min.—ppm				Peak: _____ ppm	
Max.—ppm				Rolling Avg.: _____ ppm	

**Test Configuration 3 (i.e., 6-inch Sash Opening)**

<b>Sash Configuration:</b>	_____		
Opening Dimensions:	Width: ____ in.	Height: ____ in.	Area: ____ ft <sup>2</sup>
	Additional Area: ____ ft <sup>2</sup>	Total Opening Area: ____ ft <sup>2</sup>	
Baffle/Slot Configuration:	_____		
Comments:			

**Face Velocity Traverse Test:**

	Col. 1	Col. 2	Col. 3	Col. 4	Col. 5	Col. 6	Col. 7	Col. 8	Col. 9	Col. 10	Col. 11	Col. 12	
Row 1													Avg. Velocity: ____ fpm Min. Velocity: ____ fpm Max. Velocity: ____ fpm Exhaust Flow: ____ cfm  Monitor: _____

**Test Configuration 4 (i.e., Horizontal Sash Openings)**

<b>Sash Configuration:</b> _____	
Opening Dimensions:	Width: ____ in.      Height: ____ in.      Area: ____ ft <sup>2</sup>
	Additional Area: ____ ft <sup>2</sup> Total Opening Area: ____ ft <sup>2</sup>
Baffle/Slot Configuration: _____	
Comments:	

**Cross-Draft Velocity Test Results:**

	<b>Horizontal</b>			<b>Vertical</b>			<b>Perpendicular</b>		
	Left	Center	Right	Left	Center	Right	Left	Center	Right
Min. fpm									
Max. fpm									
Avg. fpm									

**Face Velocity Traverse Test: Left Opening**

	Col. 1	Col. 2	Col. 3	Col. 4	Col. 5	Col. 6	Col. 7	Col. 8	Col. 9	Col. 10	Col. 11	Col. 12	
Row 1													Avg. Velocity: ____ fpm
Row 2													Min. Velocity: ____ fpm
Row 3													Max. Velocity: ____ fpm
Row 4													Exhaust Flow: ____ cfm
Row 5													Monitor: _____
Row 6													
Row 7													
Row 8													
Row 9													
Row 10													
Row 11													
Row 12													

**Airflow Visualization Tests (smoke) Results: Left Opening**

<b>Low Volume Rating:</b>	<input type="checkbox"/> Fail <input type="checkbox"/> Low Pass/Poor <input type="checkbox"/> Pass/Fair <input type="checkbox"/> High Pass/Good <input type="checkbox"/> N/A
Comments:	
<b>High Volume Rating:</b>	<input type="checkbox"/> Fail <input type="checkbox"/> Low Pass/Poor <input type="checkbox"/> Pass/Fair <input type="checkbox"/> High Pass/Good <input type="checkbox"/> N/A
<b>Approximate Clearance Time:</b>	<input type="checkbox"/> Fail (>2 min.) <input type="checkbox"/> Slow (1–2 min.) <input type="checkbox"/> Fair (30 sec.–1 min.) <input type="checkbox"/> Good (<30 sec.)
Comments:	

**Face Velocity Traverse Test: Center Opening**

	Col. 1	Col. 2	Col. 3	Col. 4	Col. 5	Col. 6	Col. 7	Col. 8	Col. 9	Col. 10	Col. 11	Col. 12	
Row 1													Avg. Velocity: _____ fpm
Row 2													Min. Velocity: _____ fpm
Row 3													Max. Velocity: _____ fpm
Row 4													Exhaust Flow: _____ cfm
Row 5													
Row 6													Monitor: _____
Row 7													
Row 8													
Row 9													
Row 10													

**Airflow Visualization Tests (smoke) Results: Center Opening**

<b>Low Volume Rating:</b>	<input type="checkbox"/> Fail <input type="checkbox"/> Low Pass/Poor <input type="checkbox"/> Pass/Fair <input type="checkbox"/> High Pass/Good <input type="checkbox"/> N/A
Comments:	
<b>High Volume Rating:</b>	<input type="checkbox"/> Fail <input type="checkbox"/> Low Pass/Poor <input type="checkbox"/> Pass/Fair <input type="checkbox"/> High Pass/Good <input type="checkbox"/> N/A
<b>Approximate Clearance Time:</b>	<input type="checkbox"/> Fail (>2 min.) <input type="checkbox"/> Slow (1–2 min.) <input type="checkbox"/> Fair (30 sec.–1 min.) <input type="checkbox"/> Good (<30 sec.)
Comments:	

**Face Velocity Traverse Test: Right Opening**

	Col. 1	Col. 2	Col. 3	Col. 4	Col. 5	Col. 6	Col. 7	Col. 8	Col. 9	Col. 10	Col. 11	Col. 12	
Row 1													Avg. Velocity: _____ fpm Min. Velocity: _____ fpm Max. Velocity: _____ fpm Exhaust Flow: _____ cfm  Monitor: _____
Row 2													
Row 3													
Row 4													
Row 5													
Row 6													
Row 7													
Row 8													
Row 9													
Row 10													

**Airflow Visualization Tests (smoke) Results: Right Opening**

<b>Low Volume Rating:</b>	<input type="checkbox"/> Fail <input type="checkbox"/> Low Pass/Poor <input type="checkbox"/> Pass/Fair <input type="checkbox"/> High Pass/Good <input type="checkbox"/> N/A
Comments:	
<b>High Volume Rating:</b>	<input type="checkbox"/> Fail <input type="checkbox"/> Low Pass/Poor <input type="checkbox"/> Pass/Fair <input type="checkbox"/> High Pass/Good <input type="checkbox"/> N/A
<b>Approximate Clearance Time:</b>	<input type="checkbox"/> Fail (>2 min.) <input type="checkbox"/> Slow (1–2 min.) <input type="checkbox"/> Fair (30 sec.–1 min.) <input type="checkbox"/> Good (<30 sec.)
Comments:	

**Tracer Gas Containment Test Results:**

<b>Test Series 1</b>		Mannequin Height: _____ in.			
Ejector Location:		Breathing Zone Height: _____ in. (23 in.)			
<b>Position</b>	<b>1 Left</b>	<b>2 Center</b>	<b>3 Right</b>	<b>Pos. Control Level</b>	<b>Opening Scan</b>
Avg.—ppm				Max. Avg.: _____ ppm	<b>Max.: _____ ppm</b>
Min.—ppm				Peak: _____ ppm	<b>Grid Location:</b>
Max.—ppm				Rolling Avg.: _____ ppm	

<b>Test Series 2</b>		Mannequin Height: _____ in.		
Ejector Location:		Breathing Zone Height: _____ in. (18 in.)		
<b>Position</b>	<b>1 Left</b>	<b>2 Center</b>	<b>3 Right</b>	<b>Control Level</b>
Avg.—ppm				Max. Avg.: _____ ppm
Min.—ppm				Peak: _____ ppm
Max.—ppm				Rolling Avg.: _____ ppm

**Performance Rating:**  Pass  Fail

**Overall Comments:**

## VAV Laboratory Hood Test Form

---

### Test Room Supply Air VAV Controls Verification

Type of Controls: _____ Manufacturer: _____ Calibration Date: ____/____/____ Range of Volume: _____cfm to _____cfm (from TAB Report) Response Time: _____
--

### Test Room Exhaust System VAV Controls Verification

Type of Controls: _____ Manufacturer: _____ Calibration Date: ____/____/____ Range of Volume: _____cfm to _____cfm (from TAB Report) Response Time: _____
--

### Dynamic VAV Response and Stability Tests Results:

Parameter	Value	Notes
Avg. Steady State Flow (cfm or fpm)— Sash Closed	SSQ <sub>Avg</sub> SC =	
Avg. Steady State Flow (cfm or fpm)— Sash Open	SSQ <sub>Avg</sub> SO =	
Response Time to achieve 90% of Steady State Flow/Velocity—(sec.)	RT =	
Velocity Overshoot—Max. Deviation %	MD% =	

### Comments:

--

### Attach Response and Stability Plot:

Note: Although operation of VAV controls can be critical to fume hood performance, ensuring proper operation may not be the responsibility of the fume hood manufacturer unless operating in their test area.

## Test Equipment Calibration Information

---

**Detector—Tracer Gas:**

Instrument Name:	Manufacturer:
Model #:	Last Calibration Date:
Serial #:	

**Recorder—Strip Chart or Data Logger:**

Instrument Name:	Manufacturer:
Model #:	Last Calibration Date:
Serial #:	

**Thermal Anemometer:**

Instrument Name:	Manufacturer:
Model #:	Last Calibration Date:
Serial #:	

**Smoke Generator:**

Instrument Name:	Manufacturer:
Model #:	Last Calibration Date:
Serial #:	

**Pressure Meters:**

Instrument Name:	Manufacturer:
Model #:	Last Calibration Date:
Serial #:	



**APPENDIX B – AU TEST FORMS AND DATA SHEETS**

# Hood Inspection Form

Test Date: \_\_\_\_\_

Type of Test:  As Used Performance Test

Lab Hood Manufacturer: \_\_\_\_\_

Address: \_\_\_\_\_ Tel: \_\_\_\_\_

\_\_\_\_\_ Web: \_\_\_\_\_

Hood ID: _____	Hood Type: _____
Hood Model: _____	
Serial Number: _____	Size: _____ ft

## Hood Design Features:

Super Structure:	Material of Construction: _____	Exterior Dimensions	Height: _____ in.
			Width: _____ in.
			Depth: _____ in.
Sash:	<input type="checkbox"/> Vertical	Number of Sashes: _____	Baffle: <input type="checkbox"/> Adjustable Internal
	<input type="checkbox"/> Horizontal	Number of Sash Panels: _____	<input type="checkbox"/> Adjustable External
	<input type="checkbox"/> Combination	Panel Widths: _____ in.	<input type="checkbox"/> Automatic Adjustable
	<input type="checkbox"/> Hinged	Vertical Opening:	<input type="checkbox"/> Fixed
	<input type="checkbox"/> None/Fixed	Max. Opening Height: _____ in.	<input type="checkbox"/> None
	<input type="checkbox"/> Automated Sash Closure Device	Max. Opening Width: _____ in.	
		Horizontal Opening:	
		Max. Opening Height: _____ in.	
		Max. Opening Width: _____ in.	
Sash Stop:	<input type="checkbox"/> Yes <input type="checkbox"/> No	Height: _____ in.	Number of Slots: _____
Airfoil Sill:	<input type="checkbox"/> Yes <input type="checkbox"/> No	Liner Material: _____	
Bypass Grille:	<input type="checkbox"/> Yes <input type="checkbox"/> No <input type="checkbox"/> Restricted	Recessed Work Surface:	<input type="checkbox"/> Yes <input type="checkbox"/> No
Light Type:	_____	Interior Height:	_____ in.
External Access to Lights:	<input type="checkbox"/> Yes <input type="checkbox"/> No	Interior Depth (Sash Plane to Baffle):	_____ in.
		Interior Work Surface Area:	_____ ft <sup>2</sup>
Services:	_____		
Auxiliary Air Supply:	<input type="checkbox"/> Yes <input type="checkbox"/> No	Supply Outlet Dimensions: Width: _____ in. Depth: _____ in.	
Mechanical Air Supply:	<input type="checkbox"/> Yes <input type="checkbox"/> No	Description:	
Additional Comments:			

**Hood Monitor Information:**

Factory Installed:	<input type="checkbox"/> Yes	<input type="checkbox"/> No			
Manufacturer:			Model:	_____	
Type:	<input type="checkbox"/> Velocity	<input type="checkbox"/> Pressure	<input type="checkbox"/> Flow	<input type="checkbox"/> Other—Describe:	
Display Units:			Stated Accuracy/Precision:	_____	
Alarm:	<input type="checkbox"/> Visual	<input type="checkbox"/> Audible			

# Laboratory Hood Performance Test Results

Type of Test:  As Used Performance Test

Hood Model: \_\_\_\_\_ Size: \_\_\_\_\_ Type: \_\_\_\_\_

Name of Person Conducting Test: \_\_\_\_\_ Test Date: \_\_\_\_\_

## Test Configuration 1 (i.e., Vertical Sash Open 80%)

<b>Sash Configuration:</b>	_____		
Opening Dimensions:	Width: _____ in.	Height: _____ in.	Area: _____ ft <sup>2</sup>
	Additional Area: _____ ft <sup>2</sup>	Total Opening Area: _____ ft <sup>2</sup>	
Baffle/Slot Configuration:	_____		
Comments:	_____ _____		

## Lab Environment Tests

	<u>Design Sash Opening</u>	<u>Sash Closed</u>
Room Differential Pressure:	_____ in.H <sub>2</sub> O	_____ in.H <sub>2</sub> O
Room Temperature:	_____ °F	_____ °F

## Cross-Draft Velocity Test Results:

	Horizontal			Vertical			Perpendicular		
	Left	Center	Right	Left	Center	Right	Left	Center	Right
Min. fpm									
Max. fpm									
Avg. fpm									

**Face Velocity Traverse Test:**

	Col. 1	Col. 2	Col. 3	Col. 4	Col. 5	Col. 6	Col. 7	Col. 8	Col. 9	Col. 10	Col. 11	Col. 12	
Row 1													Avg. Velocity: _____ fpm
Row 2													Min. Velocity: _____ fpm
Row 3													Max. Velocity: _____ fpm
Row 4													Exhaust Flow: _____ cfm
Row 5													
Row 6													Monitor: _____
Row 7													Monitor
Row 8													(sash closed): _____
Row 9													
Row 10													

**Auxiliary—Downflow Velocity Traverse Test:**

	Col. 1	Col. 2	Col. 3	Col. 4	Col. 5	Col. 6	Col. 7	Col. 8	Col. 9	Col. 10	Col. 11	Col. 12	
Row 1													Avg. Velocity: _____ fpm
Row 2													Min. Velocity: _____ fpm
Row 3													Max. Velocity: _____ fpm
Row 3													Supply Flow: _____ cfm

**Airflow Visualization Tests (smoke) Results:**

<b>Low Volume Rating:</b>	<input type="checkbox"/> Fail <input type="checkbox"/> Low Pass/Poor <input type="checkbox"/> Pass/Fair <input type="checkbox"/> High Pass/Good <input type="checkbox"/> N/A
Comments:	
<b>High Volume Rating:</b>	<input type="checkbox"/> Fail <input type="checkbox"/> Low Pass/Poor <input type="checkbox"/> Pass/Fair <input type="checkbox"/> High Pass/Good <input type="checkbox"/> N/A
<b>Approximate Clearance Time:</b>	<input type="checkbox"/> Fail (>2 min.) <input type="checkbox"/> Slow (1–2 min.) <input type="checkbox"/> Fair (30 sec.–1 min.) <input type="checkbox"/> Good (<30 sec.)
Comments:	

**Dynamic VAV Response and Stability Tests:**

(See additional notes under VAV Laboratory Hood Test Form, page A-15)

VAV Response Time: \_\_\_\_\_ sec.

VAV Stability Steady State Flow/Velocity Variation Percentage: \_\_\_\_\_ %

**Test Configuration 2 (i.e., Horizontal Sash Openings)**

<b>Sash Configuration:</b> _____	
Opening Dimensions:	Width: ____ in.      Height: ____ in.      Area: ____ ft <sup>2</sup> Additional Area: ____ ft <sup>2</sup> Total Opening Area: ____ ft <sup>2</sup>
Baffle/Slot Configuration: _____	
Comments: _____	

**Cross-Draft Velocity Test Results:**

	<b>Horizontal</b>			<b>Vertical</b>			<b>Perpendicular</b>		
	Left	Center	Right	Left	Center	Right	Left	Center	Right
Min. fpm									
Max. fpm									
Avg. fpm									

**Face Velocity Traverse Test: Left Opening**

	Col. 1	Col. 2	Col. 3	Col. 4	Col. 5	Col. 6	Col. 7	Col. 8	Col. 9	Col. 10	Col. 11	Col. 12	
Row 1													Avg. Velocity: ____ fpm
Row 2													Min. Velocity: ____ fpm
Row 3													Max. Velocity: ____ fpm
Row 4													Exhaust Flow: ____ cfm
Row 5													Monitor: _____
Row 6													
Row 7													
Row 8													
Row 9													
Row 10													
Row 11													
Row 12													

**Airflow Visualization Tests (smoke) Results: Left Opening**

<b>Low Volume Rating:</b>	<input type="checkbox"/> Fail <input type="checkbox"/> Low Pass/Poor <input type="checkbox"/> Pass/Fair <input type="checkbox"/> High Pass/Good <input type="checkbox"/> N/A
Comments:	
<b>High Volume Rating:</b>	<input type="checkbox"/> Fail <input type="checkbox"/> Low Pass/Poor <input type="checkbox"/> Pass/Fair <input type="checkbox"/> High Pass/Good <input type="checkbox"/> N/A
<b>Approximate Clearance Time:</b>	<input type="checkbox"/> Fail (>2 min.) <input type="checkbox"/> Slow (1–2 min.) <input type="checkbox"/> Fair (30 sec.–1 min.) <input type="checkbox"/> Good (<30 sec.)
Comments:	

**Face Velocity Traverse Test: Center Opening**

	Col. 1	Col. 2	Col. 3	Col. 4	Col. 5	Col. 6	Col. 7	Col. 8	Col. 9	Col. 10	Col. 11	Col. 12	
Row 1													Avg. Velocity: _____ fpm
Row 2													Min. Velocity: _____ fpm
Row 3													Max. Velocity: _____ fpm
Row 4													Exhaust Flow: _____ cfm
Row 5													
Row 6													Monitor: _____
Row 7													
Row 8													
Row 9													
Row 10													

**Airflow Visualization Tests (smoke) Results: Center Opening**

<b>Low Volume Rating:</b>	<input type="checkbox"/> Fail <input type="checkbox"/> Low Pass/Poor <input type="checkbox"/> Pass/Fair <input type="checkbox"/> High Pass/Good <input type="checkbox"/> N/A
Comments:	
<b>High Volume Rating:</b>	<input type="checkbox"/> Fail <input type="checkbox"/> Low Pass/Poor <input type="checkbox"/> Pass/Fair <input type="checkbox"/> High Pass/Good <input type="checkbox"/> N/A
<b>Approximate Clearance Time:</b>	<input type="checkbox"/> Fail (>2 min.) <input type="checkbox"/> Slow (1–2 min.) <input type="checkbox"/> Fair (30 sec.–1 min.) <input type="checkbox"/> Good (<30 sec.)
Comments:	

**Face Velocity Traverse Test: Right Opening**

	Col. 1	Col. 2	Col. 3	Col. 4	Col. 5	Col. 6	Col. 7	Col. 8	Col. 9	Col. 10	Col. 11	Col. 12	
Row 1													Avg. Velocity: _____ fpm
Row 2													Min. Velocity: _____ fpm
Row 3													Max. Velocity: _____ fpm
Row 4													Exhaust Flow: _____ cfm
Row 5													
Row 6													Monitor: _____
Row 7													
Row 8													
Row 9													
Row 10													

**Airflow Visualization Tests (smoke) Results: Right Opening**

<b>Low Volume Rating:</b>	<input type="checkbox"/> Fail <input type="checkbox"/> Low Pass/Poor <input type="checkbox"/> Pass/Fair <input type="checkbox"/> High Pass/Good <input type="checkbox"/> N/A
Comments:	
<b>High Volume Rating:</b>	<input type="checkbox"/> Fail <input type="checkbox"/> Low Pass/Poor <input type="checkbox"/> Pass/Fair <input type="checkbox"/> High Pass/Good <input type="checkbox"/> N/A
<b>Approximate Clearance Time:</b>	<input type="checkbox"/> Fail (>2 min.) <input type="checkbox"/> Slow (1–2 min.) <input type="checkbox"/> Fair (30 sec.–1 min.) <input type="checkbox"/> Good (<30 sec.)
Comments:	

**Performance Rating:**  Pass     Fail

**Overall Comments:**



## Test Equipment Information

---

**Thermal Anemometer:**

Instrument Name:	Manufacturer:
Model #:	Last Calibration Date:
Serial #:	

**Smoke Generator:**

Instrument Name:	Manufacturer:
Model #:	Last Calibration Date:
Serial #:	

**Pressure Meters:**

Instrument Name:	Manufacturer:
Model #:	Last Calibration Date:
Serial #:	